



PLEASE READ THE ENTIRE CONTENTS OF THIS MANUAL PRIOR TO INSTALLATION AND OPERATION. BY PROCEEDING YOU AGREE THAT YOU FULLY UNDERSTAND AND COMPREHEND THE FULL CONTENTS OF THIS MANUAL. FORWARD THIS MANUAL TO ALL OPERATORS. FAILURE TO OPERATE THIS EQUIPMENT AS DIRECTED MAY CAUSE INJURY OR DEATH.

REV D 04-19-11  
PN# 5900172

## INSTALLATION AND OPERATION MANUAL

### MODEL: R715 TIRE CHANGER

FOR SERVICING  
AUTOMOBILE  
AND LIGHT TRUCK  
SINGLE PIECE  
TIRES / WHEELS



Keep this operation manual near the machine at all times. Make sure that ALL USERS read this manual.

#### SHIPPING DAMAGE CLAIMS

When this equipment is shipped, title passes to the purchaser upon receipt from the carrier. Consequently, claims for the material damaged in shipment must be made by the purchaser against the transportation company at the time shipment is received.

#### BE SAFE

Your new Ranger tire changer was designed and built with safety in mind. However, your overall safety can be increased by proper training and thoughtful operation on the part of the operator. DO NOT operate or repair this equipment without reading this manual and the important safety instructions shown inside.



1645 Lemonwood Dr.  
Santa Paula, CA. 93060, USA  
Toll Free: 1-800-253-2363  
Tel: 1-805-933-9970  
Fax: 1-805-933-9160  
[www.rangerproducts.com](http://www.rangerproducts.com)

# R715

## RimGuard™ Swing-Arm Tire Changer

This instruction manual has been prepared especially for you.

Your new tire changer is the result of over 25 years of continuous research, testing and development and is the most technically advanced tire changer on the market today.

The manner in which you care for and maintain your tire changer will have a direct effect on its overall performance and longevity.

# READ THIS ENTIRE MANUAL BEFORE OPERATION BEGINS.

RECORD HERE THE FOLLOWING INFORMATION  
WHICH IS LOCATED ON THE SERIAL NUMBER DATA PLATE.

Serial No. \_\_\_\_\_

Model No. \_\_\_\_\_

Manufacturing date \_\_\_\_\_

### PRODUCT WARRANTY

Your new tire changer is covered under warranty for one year on equipment structure; one year on all operating components and tooling/accessories, to the original purchaser, to be free of defects in material and workmanship. The manufacturer shall repair or replace at their option for this period those parts returned to the factory freight prepaid which prove upon inspection to be defective. The manufacturer will pay labor costs for the first 12 months only on parts returned as previously described.

The warranty does not extend to...

- ◆ defects caused by ordinary wear, abuse, misuse, shipping damage, improper installation, voltage or lack of required maintenance;
- ◆ damages resulting from purchaser's neglect or failure to operate products in accordance with instructions provided in the owner's manual(s) and/or other accompanying instructions supplied;
- ◆ normal wear items or service normally required to maintain the product in a safe operating condition;
- ◆ any component damaged in shipment;
- ◆ other items not listed but may be considered general wear parts;
- ◆ damage caused by rain, excessive humidity, corrosive environments or other contaminants.

**THESE WARRANTIES DO NOT EXTEND TO ANY COSMETIC DEFECT NOT INTERFERING WITH EQUIPMENT FUNCTIONALITY OR ANY INCIDENTAL, INDIRECT, OR CONSEQUENTIAL LOSS, DAMAGE, OR EXPENSE THAT MAY RESULT FROM ANY DEFECT, FAILURE, OR MALFUNCTION OF A BENDPAK INC./ RANGER PRODUCT OR THE BREACH OR DELAY IN PERFORMANCE OF THE WARRANTY.**

## WARRANTY IS NOT VALID UNLESS WARRANTY CARD IS RETURNED.

### NOTE:

Every effort has been taken to ensure complete and accurate instructions have been included in this manual, however, possible product updates, revisions and or changes may have occurred since this printing. BendPak Ranger reserves the right to change specifications without incurring any obligation for equipment previously or subsequently sold. Not responsible for typographical errors.

# TABLE OF CONTENTS



	Page #
Warranty .....	2
Operator Protection .....	3
Section 1: Definitions of Hazard Levels .....	4
Owner's Responsibility .....	4
Section 2: Safety Instructions .....	5
Section 3: Tire and Wheel Service Safety Instructions ..	6
Section 4: Description of Parts .....	7
Section 5: Specifications / Tools Required .....	8
Section 6: Lifting / Uncrating Instructions .....	9-10
Section 7: Installation Location .....	11
Section 8: Assembly .....	12
Section 9: Anchoring / Air Source/ Oiler Adjustment ...	13
Section 10: Electrical / Wiring Instructions .....	14-15
Section 11: Operating Instruction .....	16
Bead Loosening and Demounting .....	16
Important Wheel Mounting Instructions ....	17
Wheel Clamp Adjustments .....	18
Section 12: Custom and Special Wheels .....	22
Demounting Tube Tires .....	22
Section 13: Mounting .....	22-24
Section 14: Mounting Tube Type Tires .....	25
Section 15: Inflation / Inflation Pedal Operation .....	25
Section 16: Tire Inflation .....	26
Stages Of Inflation .....	26
Stage One: Bead Sealing .....	26
Stage Two: Bead Seating .....	26
Stage Three: Inflation .....	27
Section 17: Maintenance Instructions .....	28
Mount / Demount Head .....	29
Air Dryer / Oiler .....	29
Turntable Drive Belt .....	30
Transmission Oil Inspection / Lubrication ...	31
Critical Safety Warnings / Instructions .....	32
Maintenance Notes /Record .....	33
Parts Breakdown .....	34

Failure to follow danger, warning, and caution instructions may lead to serious personal injury or death to operator or bystander or damage to property.

Do not operate this machine until you read and understand all the dangers, warnings and cautions in this manual.

For additional copies  
or further information, contact:  
BendPak Inc. / Ranger Products  
1645 Lemonwood Dr.,  
Santa Paula, CA. 93060  
1-805-933-9970  
www.bendpak.com  
www.rangerproducts.com



## OPERATOR PROTECTIVE EQUIPMENT

Personal protective equipment helps make tire changing safer. However, equipment does not take the place of safe operating practices. Always wear durable work clothing during tire service activity. Shop aprons or shop coats may also be worn, however loose fitting clothing should be avoided. Tight fitting leather gloves are recommended to protect operators hands when handling worn tires and wheels. Sturdy leather work shoes with steel toes and oil resistant soles should be used by tire service personnel to help prevent injury in typical shop activities.

Eye protection is essential during tire service activity. Safety glasses with side shields, goggles, or face shields are acceptable. Back belts provide support during lifting activities and are also helpful in providing operator protection. Consideration should also be given to the use of hearing protection if tire service activity is performed in an enclosed area, or if noise levels are high.



**THIS SYMBOL POINTS OUT IMPORTANT SAFETY INSTRUCTIONS WHICH IF NOT FOLLOWED COULD ENDANGER THE PERSONAL SAFETY AND/OR PROPERTY OF YOURSELF AND OTHERS AND CAN CAUSE PERSONAL INJURY OR DEATH. READ AND FOLLOW ALL INSTRUCTIONS IN THIS MANUAL BEFORE ATTEMPTING TO OPERATE THIS MACHINE.**

## SECTION 1

### DEFINITIONS OF HAZARD LEVELS

Identify the hazard levels used in this manual with the following definitions and signal words:



#### DANGER

Watch for this symbol. It Means: Immediate hazards which will result in severe personal injury or death.



#### WARNING

Watch for this symbol. It Means: Hazards or unsafe practices which could result in severe personal injury or death.



#### CAUTION

Watch for this symbol: It Means: Hazards or unsafe practices which may result in minor personal injury or product or property damage.



Watch for this symbol! It means **BE ALERT!**  
Your safety, or the safety of others, is involved!

## OWNER'S RESPONSIBILITY

To maintain machine and user safety, the responsibility of the owner is to read and follow these instructions:

- ◆ Follow all installation instructions.
- ◆ Make sure installation conforms to all applicable Local, State, and Federal Codes, Rules, and Regulations; such as State and Federal OSHA Regulations and Electrical Codes.
- ◆ Carefully check the unit for correct initial function.
- ◆ Read and follow the safety instructions. Keep them readily available for machine operators.
- ◆ Make certain all operators are properly trained, know how to safely and correctly operate the unit, and are properly supervised.
- ◆ Allow unit operation only with all parts in place and operating safely.
- ◆ Carefully inspect the unit on a regular basis and perform all maintenance as required.
- ◆ Service and maintain the unit only with authorized or approved replacement parts.
- ◆ Keep all instructions permanently with the unit and all decal's on the unit clean and visible.



Do not attempt to operate this equipment if you have never been trained on basic tire service and mounting / dismounting procedures.



## SECTION 2

### IMPORTANT SAFETY INSTRUCTIONS!

*Read these safety instructions entirely!*



1. **READ AND UNDERSTAND** all safety warning procedures before operating lift.
2. **KEEP HANDS AND FEET CLEAR.** Remove hands and feet from any moving parts.
3. **KEEP WORK AREA CLEAN.** Cluttered work areas invite injuries.
4. Consider work area environment. Do not expose equipment to rain. **DO NOT** use in damp or wet locations. Keep area well lighted.
5. **ONLY TRAINED OPERATORS** should operate this equipment. All non-trained personnel should be kept away from work area. Never let non-trained personnel come in contact with, or operate machine.
6. **USE MACHINE CORRECTLY.** Use machine in the proper manner. Never use adapters other than what is approved by the manufacturer.
7. **DO NOT** override or disable safety valves and/or devices.
8. **ALWAYS INSURE** that all safety procedures are followed before any attempt is made to work on or near the equipment.
9. **DRESS PROPERLY.** Non-skid steel-toe footwear is recommended when operating machine.
10. **GUARD AGAINST ELECTRIC SHOCK.** This equipment must be grounded while in use to protect the operator from electric shock. Never connect the green power cord wire to a live terminal. This is for ground only.

11. **DANGER!** The motor on this machine contains high voltage. Disconnect power at the receptacle before performing any electrical repairs. Secure plug so that it cannot be accidentally plugged in during service.



12. **WARNING! RISK OF EXPLOSION.** This equipment has internal arcing or sparking parts which should not be exposed to flammable vapors. This machine should not be located in a recessed area or below floor level.



13. **MAINTAIN WITH CARE.** Keep unit clean for better and safe performance. Follow manual for proper lubrication and maintenance instructions. Keep control pedals and/or buttons dry, clean and free from grease and oil.

14. **STAY ALERT.** Watch what you are doing. Use common sense. Be aware.

15. **CHECK FOR DAMAGED PARTS.** Check for condition of all moving parts, breakage of parts or any condition that may affect the machines operation. Do not use if any component is broken or damaged.

16. **NEVER** remove safety related components or device from the machine. Do not use if safety related components are damaged or missing.

17. To reduce fire hazard, keep engine/motor exterior free of oil, solvent, or excessive grease.



18. Illegible and missing warning labels must be replaced immediately. Do not use the tire changer if one or more labels are missing. Do not add any object that could prevent the operator from seeing the labels.

## SECTION 3

### TIRE AND WHEEL SERVICE SAFETY INSTRUCTIONS



Only properly trained personnel should service tires and wheels on the R715. Read all safety and operating instructions thoroughly before use. The following safety instructions are for one piece wheels only. Always refer to the manufacturer's procedures for multi-piece wheels.

**ALWAYS** wear durable personal protective work clothing and safety gear during tire service activity. Refer to page three for Operator Protective Equipment.

**ALWAYS** remove all wheel weights and the valve core to deflate the tire before servicing.

**ALWAYS** keep all working surfaces clean and free of debris.

**ALWAYS** be aware of what each person is doing and what they will do before attempting any two-person operation.

**ALWAYS** cover the electric motor and switch box before cleaning the tire changer. Be sure water or cleaner does not enter the motor or switch box.

**ALWAYS** disconnect the electric power and air supply before attempting any maintenance.

### Demounting & Mounting

**ALWAYS** clean and inspect the wheel prior to any service.

**NEVER** stand on the frame or work table while demounting or mounting a tire.

**ALWAYS** keep hands, feet, and other objects away from moving parts while the machine is turned on.

**ALWAYS** place the narrow bead seat to the outside when clamping. Failure to demount the tire from the narrow bead seat side may cause damage to the tire beads.

**ALWAYS** apply an approved rubber lubricant to rim flanges and both tire beads before demounting or mounting and seating the beads.

**NEVER** mount a tire on a damaged or rusty wheel as tire or wheel failure may result during inflation. Explosion from failure may result in severe injury or death of the operator and bystanders.

## Inflation

**ALWAYS** be sure the bead opposite the tool is in the drop center before rotating the tire when demounting or mounting to avoid damage to the tire beads.

**ALWAYS** follow all applicable Local, State, and Federal Codes, Rules, and Regulations; such as the Federal OSHA Standard Number 1910.177.

**ALWAYS** use an approved inflation chamber or inflation cage equipped with a self-gripping chuck and remote inflation gauge and valve.

**ALWAYS** inflate the tire to manufacturer's recommended cold operating pressure.

**DO NOT OVER INFLATE!** Tire or wheel failure during and after inflation may result in an explosion capable of causing severe injury or death.

**NEVER** reinflate a tire that has been run under inflated or flat without first demounting the tire and checking for wheel and tire damage.

**ALWAYS** inspect the tire interior for loose or broken cords, cuts, penetrating objects, and other damage. Discard tires that cannot be properly repaired.

**NEVER** rework, weld, heat or braze wheels.

**NEVER** strike the tire or wheel with a hammer.

**ALWAYS** be sure the tire diameter exactly matches the wheel diameter.



Tire failure under pressure can be hazardous. When possible, always place wheels inside an approved inflation chamber or cage before inflating. Use an approved remote inflation valve, hose, and gauge. **ALWAYS** wear safety goggles for eye protection. Do not stand beside the wheel or cage during inflation. Keep hands and other parts of the body out of the cage during inflation. Observe the tire pressure frequently. Do not exceed the manufacturer's recommended maximum inflation pressure. Failure to follow these instructions may cause the tire and rim to separate with tremendous force, resulting in serious personal injury or death.

## SECTION 4 DESCRIPTION OF PARTS

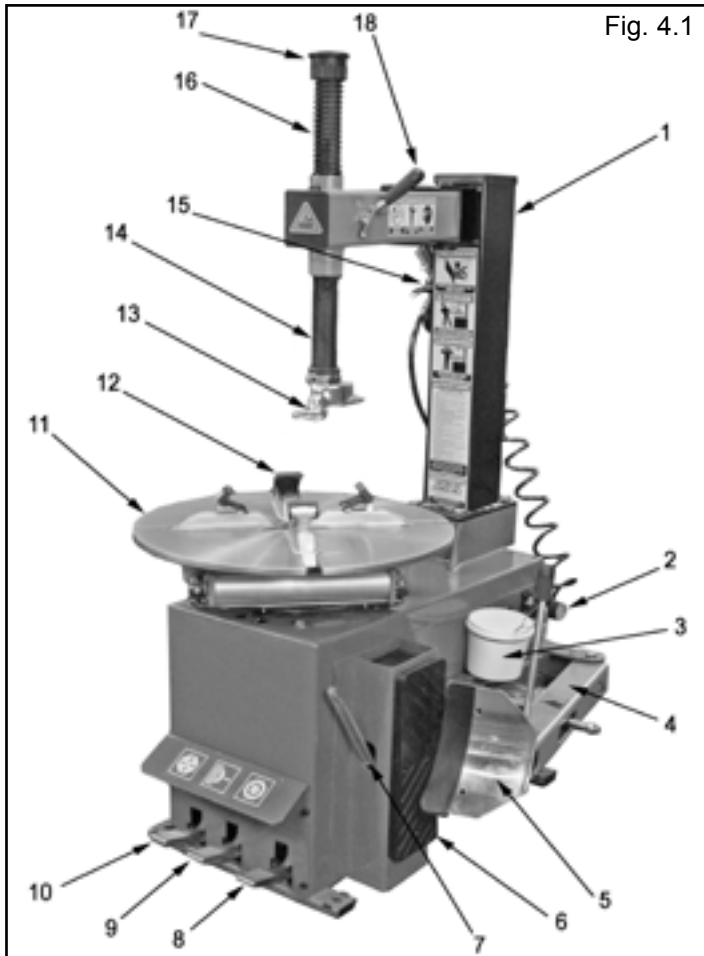

1. Tower
2. Air Drier / Oiler / Pressure Gauge (See Fig. 4.2)
3. Lube Bottle / Brush
4. Bead Breaker Arm
5. Bead Breaker Blade
6. Bead Breaker Pad
7. Bead Lifting Tool
8. Turntable Foot Pedal (See Fig. 4.3)
9. Bead Breaker Foot Pedal (See Fig. 4.3)
10. Wheel Clamp Foot Pedal (See Fig. 4.3)
11. Turntable
12. Wheel Clamps
13. Mount /Demount Head
14. Vertical Shaft
15. Inflation Gun / Hose Tire Pressure Gauge
16. Vertical Arm Spring
17. Vertical Shaft Assembly
18. Vertical Shaft Lock Handle
19. Voltage Selector Switch  
(Located on Rear of Cabinet. (See Fig. 4.4))

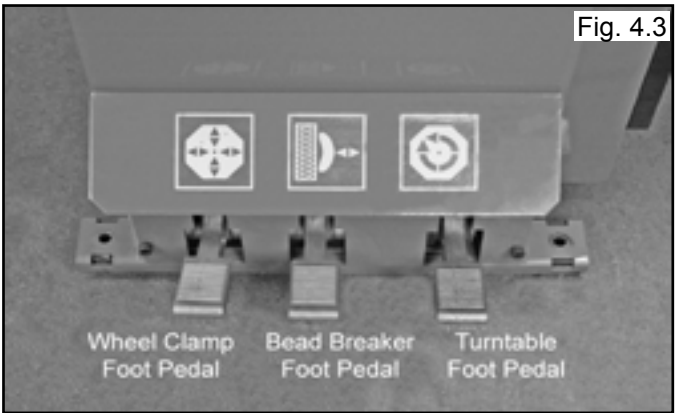

**SECTION 5  
FEATURES / SPECIFICATIONS: MODEL R715**

FEATURES / SPECIFICATIONS	MODEL R715
Type of Drive System	Air / Electric
Motor	Dual Voltage 110/220V 50/60HZ 1 Ph.
Air Requirement	140-165 PSI (10-11 BAR)
Wheel Clamping Method	4 Rim-Guard Clamps - Internal / External
Table Clamping System	Dual Pneumatic Cylinders
Bead Breaking System	Pneumatic Blade
Turntable Speed -360-Degree Rotation	6.9 Seconds
Tool Holder	Manual Lock
Adjustable Turntable Clamps	Standard
Inflation System	Standard
Water Filter	Standard
Oiler / Lubricator	Standard
Air Regulator	Standard
Bead Lifting Tool	Standard
Large Soap / Lubricator Bucket	Standard
Brush	Standard
Tower Design	Rigid Fixed
Tire Inflation	Standard
Internal Wheel Clamping Capacity *	11" – 20" (279 mm – 508 mm)
External Wheel Clamping Capacity *	10" – 19" (254 mm – 483 mm)
Turntable Tire Width Capacity (Mounting)	4.5" – 17.5" (114 mm – 444 mm)
Bead Breaker Tire Width Capacity (Demounting)	1" – 12" (25 mm – 305 mm)
Maximum Tire Diameter	40" (1016 mm)
Shipping Weight	482 lbs. (219 Kg)

Specifications are subject to change without notice.

\* NOTE: Internal and External Wheel Clamping dimensions do not translate directly to rim or tire sizes as Wheel Clamping points may vary by manufacturer.

**TOOLS REQUIRED FOR ASSEMBLY and INSTALLATION**

1. Pallet jack or forklift for moving crate.
2. Shop crane.
3. Utility knife.
4. Crow bar or pry bar.
5. Tin Snips or Sheet Metal Snips
6. Hammer.
7. Open end metric wrenches and/or socket set.
8. Phillips and Slot head screw drivers.
9. Metric Allen Key set.

Parts required but not supplied.

1. Teflon tape
2. Air fitting to match shop Air Supply line.
3. Tool Oil.
4. Anchor Bolts and Shims (if Anchoring)



## SECTION 6 LIFTING/ UNCRATING

1. The R-745 is shipped on a pallet, Approximate shipping dimensions. (See Fig 6.1)



Fig. 6.1



**CAUTION!**

Handling of the machine must be performed only with an appropriate lifting device such as a forklift or pallet jack. Only personnel who are experienced and qualified on material handling procedures should handle any transportation or moving of machine.

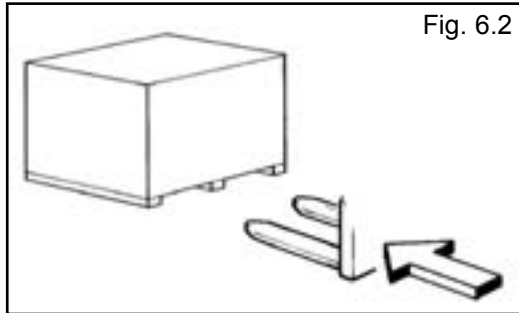

Fig. 6.2



**CAUTION!**

Be careful when cutting steel banding material as items may become loose and fall causing personal harm or injury. Always wear gloves when uncrating the machine to prevent scratches, abrasions, or cuts due to the contact with packing materials. Eye protection is essential during uncrating service activity. Safety glasses with side shields, goggles, or face shields are acceptable.

Remember to report any shipping damage to the carrier and make a notation on the delivery receipt.

## Uncrating Instructions

1. Carefully cut the plastic wrapping and remove.
2. Carefully cut open the top of the cardboard box. Either lift off box or cut side panel and remove. (See Fig 6.3)



Fig. 6.3

3. Using a crow bar or pry bar, locate the staple/nail locations and pry apart the wooden crating. Note: the entire wooden frame can be lifted off after prying the staples /nails at the base of the crate. (See Fig 6.4)



Fig. 6.4



**CAUTION!**

Secure the Tower with shop crane or personnel prior to cutting metal strapping as Tower may have shifted during shipping. Be careful as banding may snap or fly when tension is released.

4. Either cut or unscrew the metal strapping holding the Tower to the pallet and set aside. (See Fig 6.5)

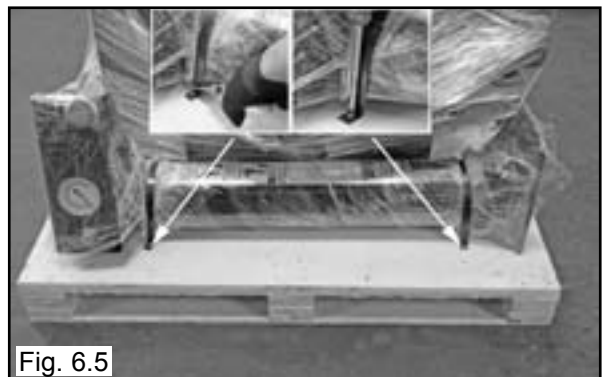

Fig. 6.5

5. Carefully remove the rest of the plastic wrapping from the Tire Changer. Keep the wrapping on the Tower assembly as it will assist in keeping the Tower/Arm assembly from moving during installation.

6. Remove the four front and rear Bolts and Nuts holding the tire changer to the pallet. (See Figs. 6.6 & 6.7)



Fig. 6.6

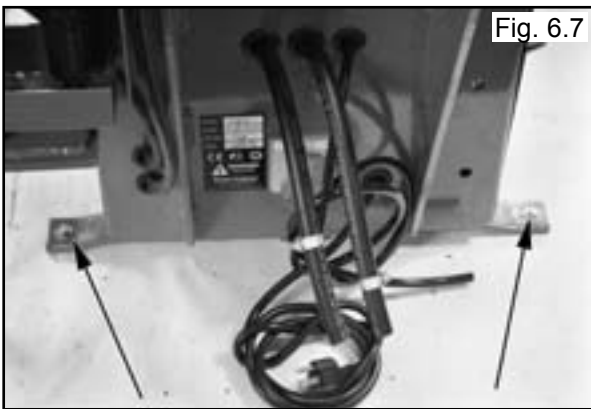

Fig. 6.7



**CAUTION!**

**Handling of the machine must be performed only with an appropriate lifting device such as a forklift or shop crane. Only personnel who are experienced and qualified on material handling procedures should handle any transportation or moving of machine.**

7. Using a shop crane or fork lift with lifting straps, remove the Tire Changer from the wooden pallet. Use only properly rated lifting straps under the Tire Changer base. (See Fig. 6.8)

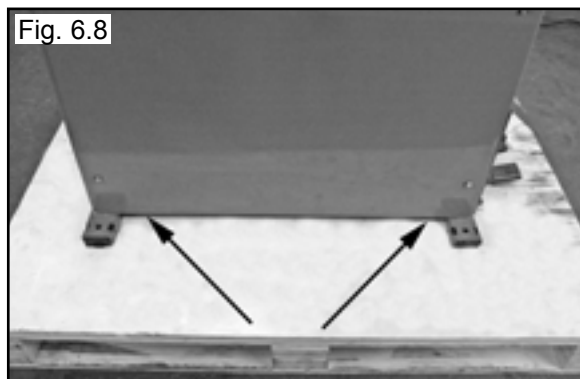

Fig. 6.8

## SECTION 7

### INSTALLATION LOCATION



**Disconnect tag and lock out** power source before attempting to install, service, relocate or perform any maintenance.

**Do not** lift or move unit without appropriately rated equipment. Be sure the unit is securely attached to any lifting device used.

**Proper unit installation is necessary for safe use and efficient operation. Proper installation also helps protect the unit from damage and makes service easier. Always keep this manual with unit.**

**Never** use the wood shipping skid for mounting the unit.

Select a location using Figures 7.1 and 7.2. The area should provide the operator with enough space to use the equipment in a safe manner. The area selected should be well lit, easy to clean and should be away from oil, grease, brake lathe chips, etc. Avoid areas where bystanders and customers may be present.

R715 Machine size is approximately:  
26" W x 36" D x 72" H

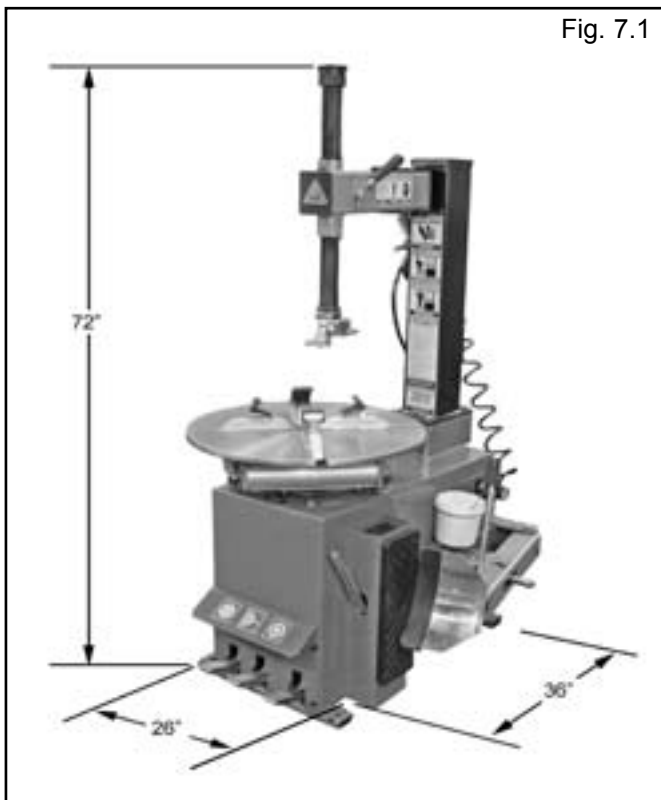

Fig. 7.1



These measurements are the tire changer's working range. Persons other than specially trained and authorized operators are expressly forbidden to enter this area.

Choose a safe location that is in compliance with current work place safety regulations.

Failure to properly install the machine can lead to improper and unsafe operation.

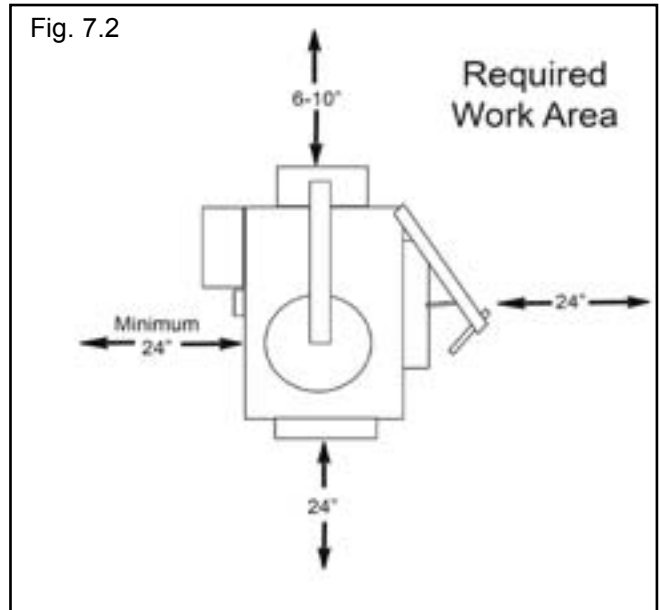
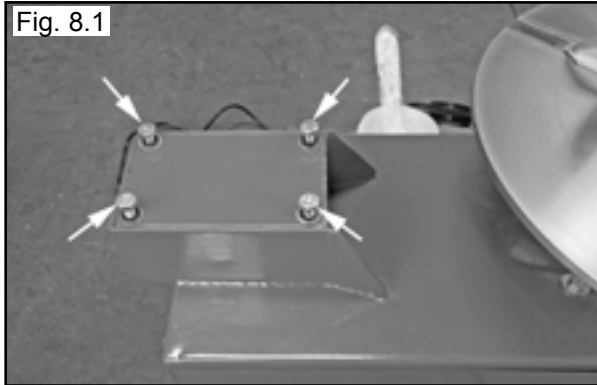

Fig. 7.2

## SECTION 8

### R715 ASSEMBLY

1. Remove the Tower Bolts. (See Fig. 8.1)



3. Using a shop crane or other lifting device, lower the Tower onto the base and align the holes.

4. Attach the Tank / Tower assembly to the base using the four bolts on the Tower Base Plate. (See Fig. 8.2)

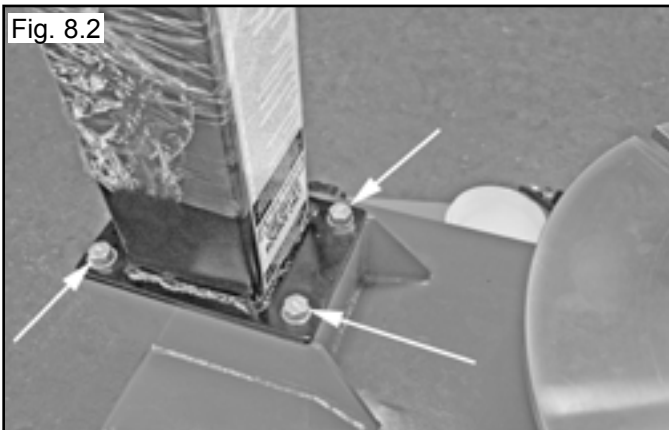

#### Swing Arm / Vertical Shaft / Mount-demount Head Assembly

1. Check the Swing Arm Assembly if necessary tighten the Swing Arm Pivot Pin Nut until the Swing Arm will not move and then back off one-half to one complete turn to allow the Swing Arm to swing freely but without any play in the assembly. (See Fig. 8.3)

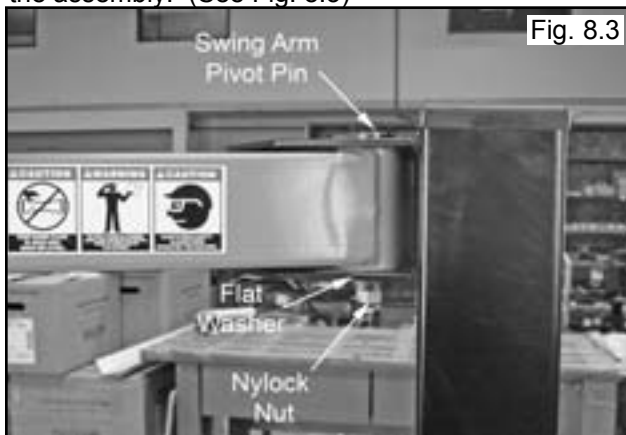

3. Raise the Vertical Shaft / Mount-demount Head assembly to the highest position and lock it in place by Pushing the Locking Handle Down.

4. Check the Socket Head Cap Screw on the Cap, Tighten if necessary. (See Fig. 8.4)

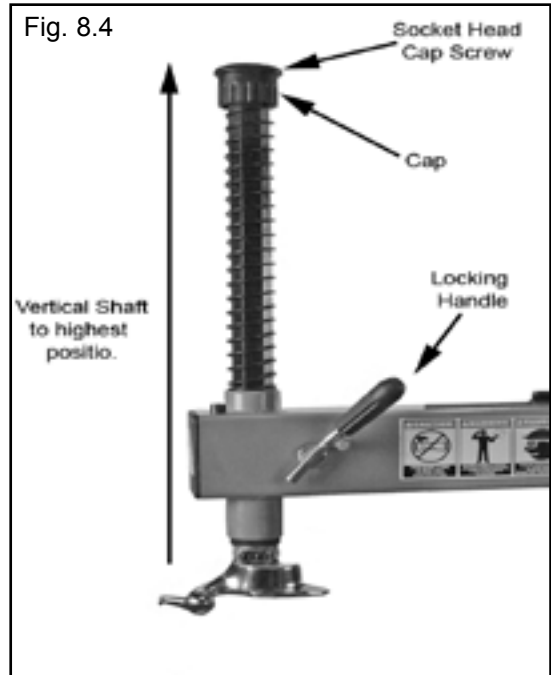

5. Check the operation of the Vertical Shaft and the Locking Handle (See Section 17, Page 29 for Lock adjustment details)

6. Check that the Mount-demount Head Bolt and Allen Set Screws are tightened. (See Fig. 8.5 - 8.6)



## SECTION 9 ANCHORING

It is not essential to anchor the machine to the floor, however, the floor must be smooth and level. When anchoring to a concrete floor use the mounting holes that are provided in the frame. Make sure the machine is solid and level and supported evenly on all anchor points. Solid shims may be used if necessary. (See Fig. 9.1)

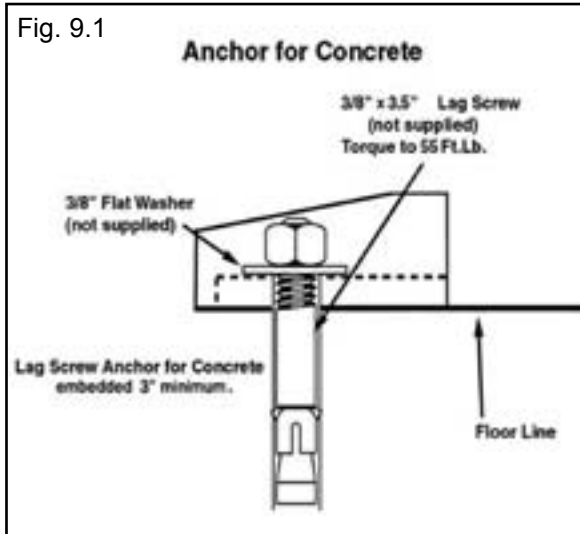

## AIR SOURCE

This model requires a 14 to 15 CFM air source at 165 PSI maximum pressure. The safe operating pressure range for this model is between 140 PSI and 165 PSI at the machine. A 1/4" ID hose (or pipe) for connection to the machine is satisfactory. Sufficient air pressure assures good performance.

1. Connect the Air Supply to the Air Drier / Oiler. A proper fitting (not supplied) to match the supply line of the air supply connection is required. Use teflon tape (not supplied) on the NPT thread of the fitting.

This connection is located on the right side of the rear of the machine. (See Fig. 9.2)

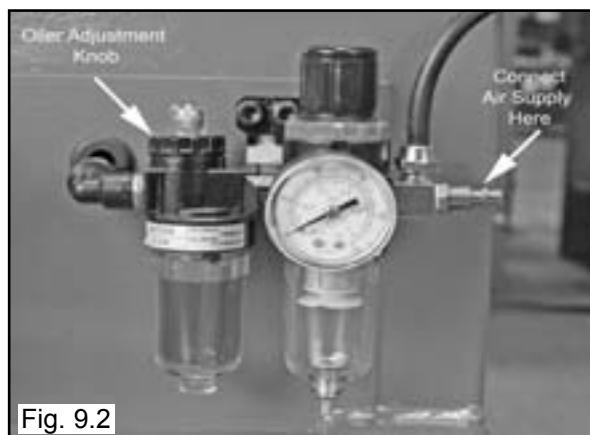

Fig. 9.2

## OILER ADJUSTMENT



### WARNING!

Failure to properly maintain proper Oil level and adjust the Oil flow may void the warranty and damage the bead breaker cylinder and other air components.

1. Check Oil Level on Oil Cup Site Glass. (See Fig. 9.3)

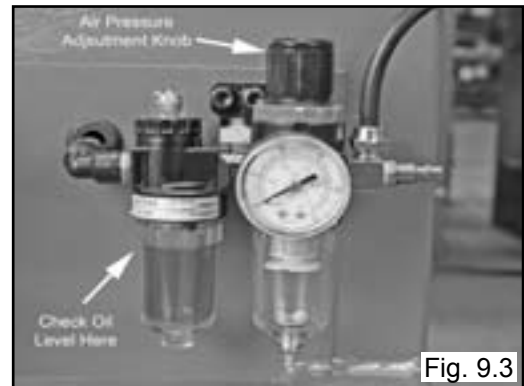

Fig. 9.3

If Oil level is low refer to Section 17, Page 29 for filling instructions.

### NOTE:

This adjustment will require two persons to perform.

2. With the Air source connected, depress the Bead Breaker Pedal to operate the Bead Breaker.
3. Observe the site glass and adjust the oil flow of the oiler by turning the Oiler Adjustment Knob so that 2-3 drops of oil drip through the site glass for each operation of the Bead Breaker Pedal. (See Fig 9.4)

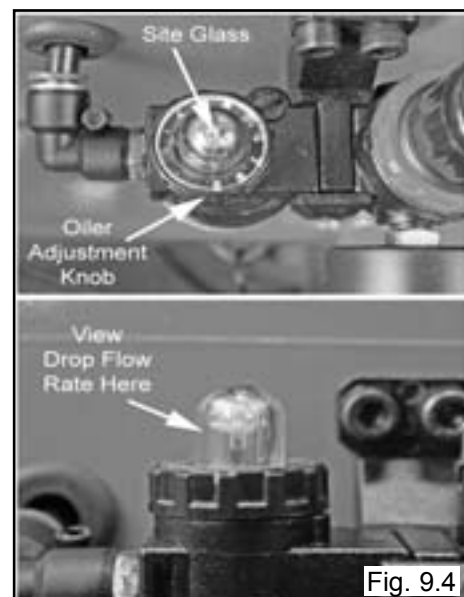

Fig. 9.4

### NOTE:

More detailed Maintenance procedures are described in Section 17 on page 29.

## SECTION 10

### ELECTRICAL SOURCE

This unit requires power from a 15 amp electrical circuit. The unit is supplied standard with a 110 Volt power cord and plug. (See Fig. 10.1)

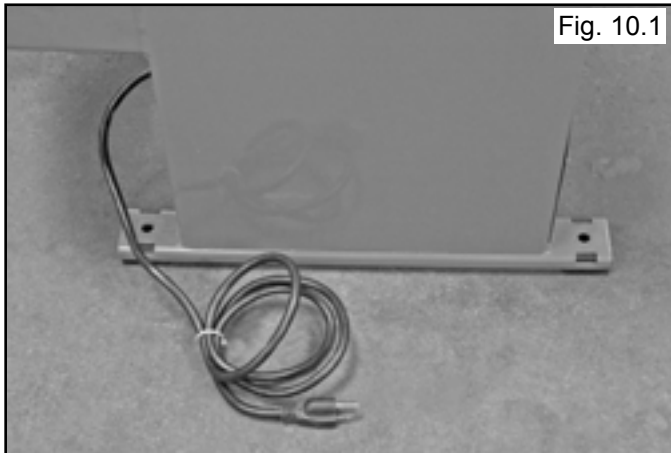

Refer to the serial tag of the machine for specific electrical requirements. Have a licensed electrical technician perform any necessary changes to the power source and power cord before plugging in the unit. The electrical source must have a solid connection between ground and building ground.



**WARNING!**  
**GUARD AGAINST ELECTRIC SHOCK.**

This equipment must be grounded while in use to protect the operator from electric shock. Never connect the green power cord wire to a live terminal. This is for ground only.



**DANGER!**

The motor on this machine contains high voltage. Disconnect power at the receptacle before performing any electrical repairs. Secure plug so that it cannot be accidentally plugged in during service.



**WARNING!**  
**RISK OF EXPLOSION.**

This equipment has internal arcing or sparking parts which should not be exposed to flammable vapors. This machine should not be located in a recessed area or below floor level.

## WIRING INSTRUCTIONS



1. Check the voltage, phase and proper amperage requirements for the motor shown on the motor plate. Wiring should be performed by a certified electrician only.
2. Overheating, short circuits and fire damage will result from inadequate wiring. Wiring must be installed in accordance with National Electric Code and local codes and standards covering electrical apparatus and wiring.
3. Be certain that adequate wire sizes are used, and that:
  - ◆ Service is of adequate amp rating.
  - ◆ The supply line has the same electrical characteristics (voltage, cycles and phase) as the motor.
  - ◆ The line wire is the proper size and that no other equipment is operated from the same line.



Check the voltage, phase and proper amperage requirements for the motor shown on the motor plate. Wiring should be performed by a certified electrician only.

### IMPORTANT NOTE:

**YOUR MACHINE HAS A DUAL VOLTAGE MOTOR** and can be run on either 110 or 220 volts.

### STANDARD WIRING IS 110 VOLTS.

See below before connecting 220 volts to your machine or serious damage to the motor/electronics will result. Have a licensed electrical technician perform any necessary changes to the power source and power cord before plugging in the unit. The electrical source must have a solid connection between ground and building ground.

Confirm voltage selector switch is positioned correctly before connecting power to your machine or serious damage to the motor/electronics will result. (See Fig. 10.2)



Refer to Page 7 Item # 19 for location of Voltage Selector Switch

# SECTION 11

## OPERATING INSTRUCTIONS

The unit must be properly operated and maintained to help avoid accidents that could damage the unit and injure the operator or bystanders. This section of the Operating Instructions manual review basic operations and use of controls. These instructions should be reviewed with all employees before they are allowed to work with the machine. Keep these instructions near the machine for easy reference.

### BEAD LOOSENING AND DEMOUNTING



#### CAUTION!

This machine may operate differently from machines you have previously operated. Practice with a regular steel wheel and tire combination to familiarize yourself with the machine's operation and function.

◆ Remember to remove all weights from both sides of the wheel. Weights left on the back side of the wheel may cause the wheel to be clamped un-level. This may result in the combination mount/demount head contacting the rim causing scratches. On alloy wheels, always rotate the wheel one turn after setting the head to insure proper wheel chucking.

◆ Always review nicks and scratches with owners of expensive wheel and tire combinations prior to servicing.

◆ Review the performance wheel section of this manual prior to servicing performance tire/wheel combinations.

1. Deflate tire completely by removing the valve core from the valve stem. (See Fig. 11.1)



2. The clamps on the table top may extend beyond the table top itself. To avoid damaging the clamps and/or wheel, move the clamps to their full inward position before positioning a tire for bead loosening.

3. Always loosen the bead on the narrow side of the wheels drop center first. (See Fig. 11.4 and page 17 for better description of the drop center)

4. Use extra care in positioning the bead breaker shoe on larger wheels/tires, and on alloy wheels. Make sure the shoe rests next to but not on the rim, and not on the tire sidewall.

5. Pull the bead breaker shoe away from the machine and roll the wheel into position.

6. Position the bead breaker shoe against the tire next to, but not on, the rim. Press the breaker pedal to actuate the shoe and loosen the bead. It may be necessary to loosen the bead in multiple locations around the tire. (See Fig. 11.2)



7. Turn wheel around and repeat procedure on the other side of the wheel. This should be the long side of the drop center. It will be easier to clamp the wheel to the table top if the lower bead is loosened last. (See Fig. 11.3)



8. Determine the mounting side of the wheel. The mounting side is the narrow side of the drop center. The tire is removed for clarity. (See Fig. 11.4 and page 17.)

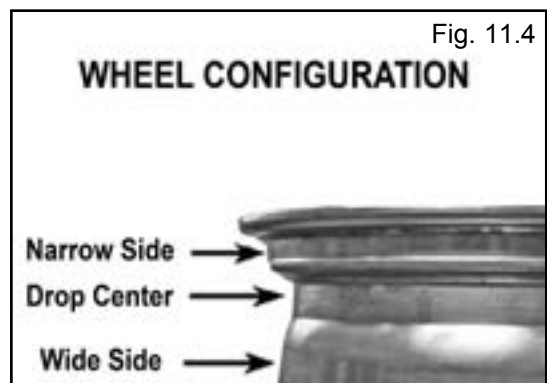





The following instructions help identify how to properly mount wheels on the tire changer turntable. Failure to follow these instructions may lead to tire and/or wheel damage, equipment damage or failure, serious personal injury or death to operator or bystanders or damage to property.

## IMPORTANT WHEEL MOUNTING INSTRUCTIONS

1. It is important to understand that tires and/or tire beads do not stretch. It is nearly impossible to mount or dismount the top bead of the tire unless the top bead of the tire is positioned deep into the drop center area of the wheel.
2. Find the position of the drop center on the wheel. Clearly identify the Drop Center, Narrow Side and Wide Side flanges.
3. The tire must ALWAYS be demounted or mounted with the wheel positioned on the turntable with the Narrow Side facing upward and the deepest part of the Drop Center facing upward.

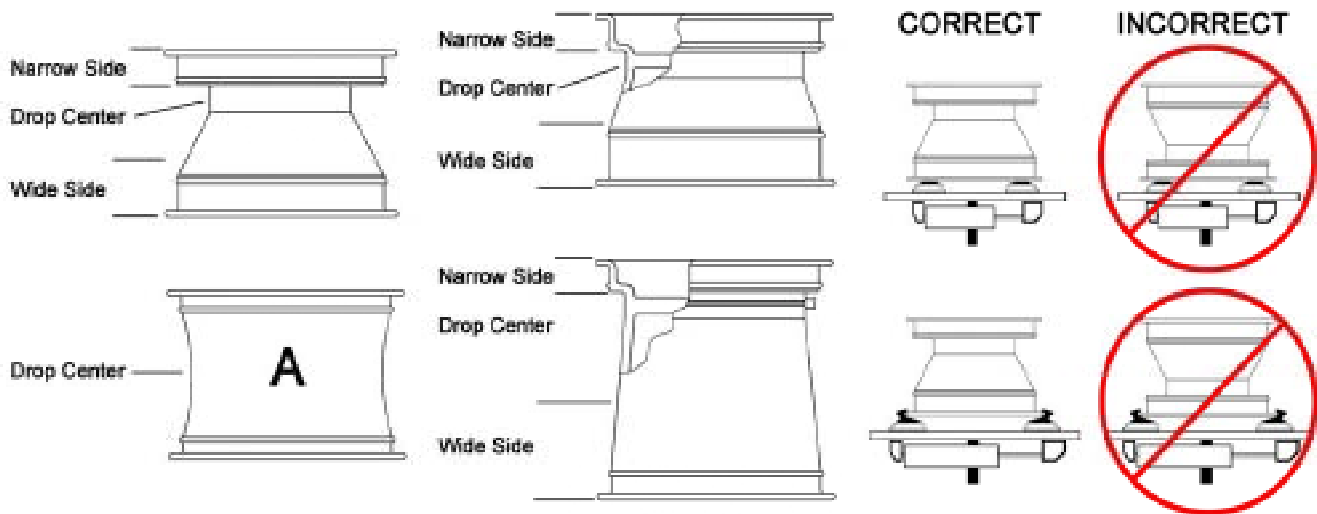

**WARNING!** - The wheel illustrated above in diagram A has little or no prominent drop center. These are not DOT approved wheel configurations. The tire or wheel - or both - can be damaged during mounting procedures causing the tire to explode under pressure, resulting in serious injury or death. If you attempt to mount/demount this type of wheel, use extreme caution.

**IMPORTANT NOTE** – Most aftermarket and many OEM performance wheels are REVERSE DROP-CENTER configurations. These wheels MUST be mounted on the turntable with the hub or wheel-face POSITIONED DOWNWARD on the turntable and the Narrow Side and deep part of the Drop Center facing upward.



## Wheel Clamp Adjustments

9. Place the Wheel Protections pads on the Wheel Clamps if desired when clamping from the outside. (See Fig. 11.5)



Fig. 11.5

10. Place tire/wheel assembly on Table Top with mounting side up. (See Fig. 11.6)



Fig. 11.6

**NOTE:**  
Clamp steel wheels from the inside (clamps push outward against wheel). Clamp mag and custom wheels from the outside (Clamps push inward against the outside rim edge). Refer to the Performance Tires and Wheels section.

11. Use the Wheel Clamp Foot Pedal to move the Clamps inward or outward. (See Fig. 11.7 & 11.8)

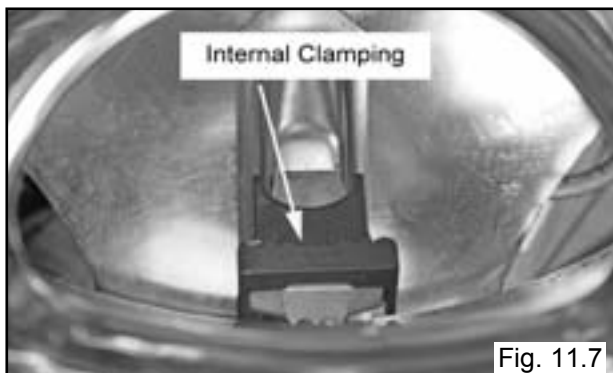

Fig. 11.7



Fig. 11.8

12. Apply tire manufacturer's approved rubber lubricant liberally to entire circumference of both upper and lower beads after loosening bead and placing on table top. (See Fig. 11.9)



Fig. 11.9

13. After the wheel is secured to the Turntable, pull the Overhead Swing Arm into position, use the Large adjusting Knob to position the Mount/Demount Head directly over the edge of the rim. (See Fig. 11.10)

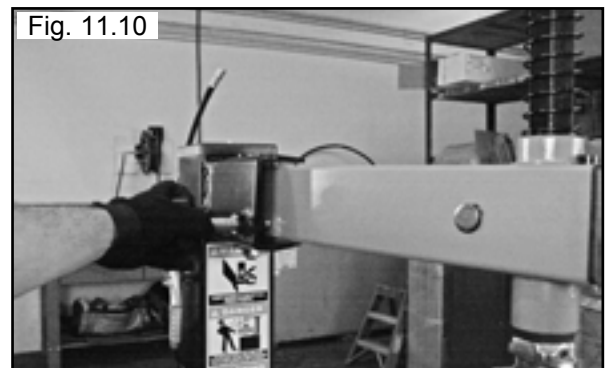
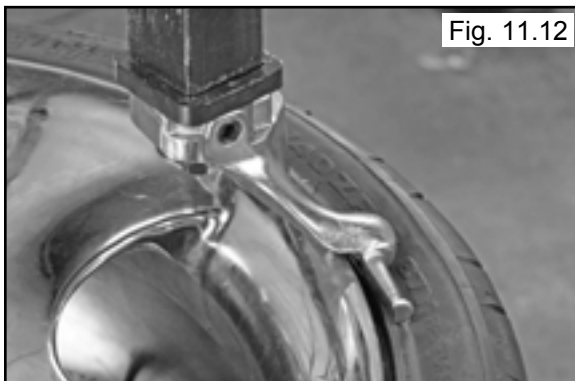

Fig. 11.10



**WARNING!**  
THE RIM AND BEAD MUST BE LIBERALLY LUBRICATED. FAILURE TO USE AN ADEQUATE LUBRICANT CAN LEAD TO THE BEAD BINDING ON THE RIM AND LEAD TO DAMAGE TO THE MOTOR AND OR VOID THE WARRANTY.

14. Push the Vertical Shaft down and position the Mount/Demount Head into contact with the rim edge. (See Fig. 11.11 - 11.12)



15. Push up on the locking handle to lock the Vertical Shaft into position. As the slide is locked, the Mount/Demount Head will move upward approximately 1/8 inch and backward 1/8 inch from the rim edge. The Mount/Demount head roller should not be in contact with the rim edge. (See Fig. 11.13)

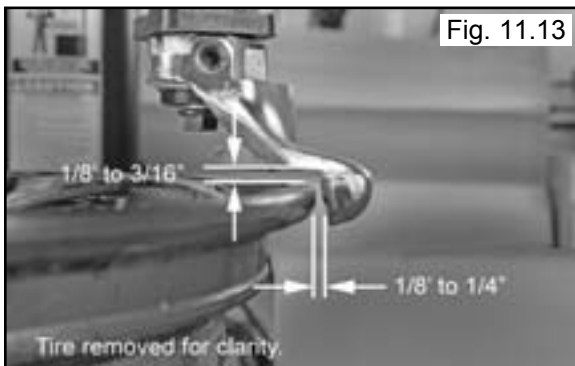

**NOTE:**  
 This clearance will be maintained as long as the Vertical Shaft remains locked. The operator may swing the arm out of the way and back into place again without needing to reposition the head when changing a like set of wheels. The tool clearance may change with machine use and should be inspected often. Failure to maintain proper clearance may result in damage to the wheel rim or tire. See page 29 for adjustment procedure.

16. Insert the smooth curved end of the Bead Lifting Tool over the “duckbill” side of the Mount/Demount Head and below the top bead of the tire. (Fig. 11.14)

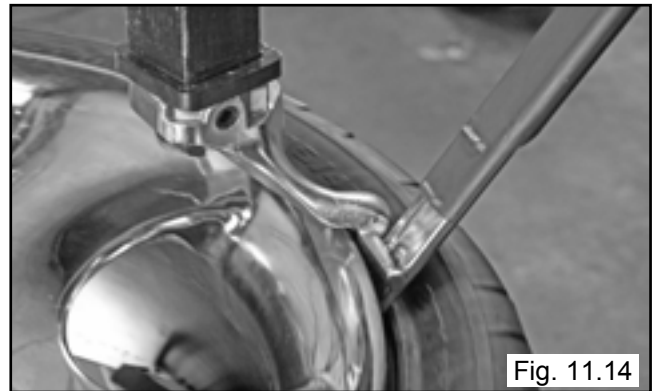

**! DANGER**

**DANGER!**  
 The Bead Lifting Tool and demount head may encounter resistance or come under load at times during the mount and demount procedures. Keep one hand firmly on the tool to avoid possible tool kick back. Use the reversing feature (lift table top pedal upwards) to back out of jam ups.

For Low Profile Tires, perform Step 17 to get the upper bead into the drop center of the wheel.

17. Push the Bead Lifting Tool down away from the wheel to lower the bead into the Drop Center while lifting up on the Table Top Pedal to rotate the turnable counter clockwise. (See Fig. 11.15)



18. Push the Bead Lifting Tool down toward the wheel to lift the tire bead up and over the “duckbill” side knob portion of the Mount/Demount Head. Hold the Bead Lifting Tool in this position. (See Fig. 11.16)

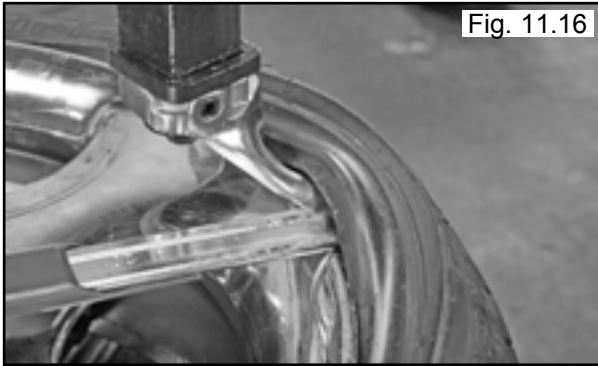

Fig. 11.16

19. Depress the Table Top Foot Pedal to rotate the wheel clockwise. (See Fig. 11.17)

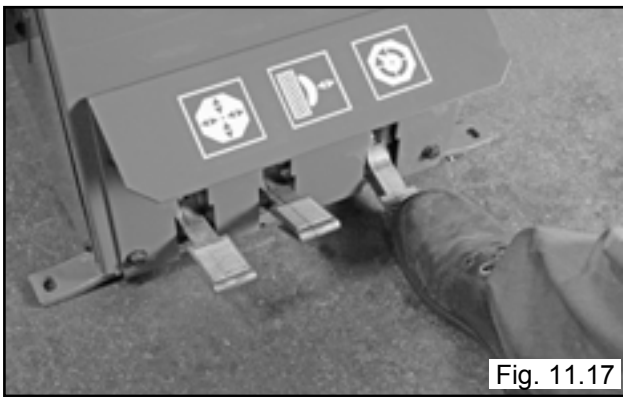

Fig. 11.17



**DANGER!**

The Bead Lifting Tool and demount head may encounter resistance or come under load at times during the mount and demount procedures. Keep one hand firmly on the tool to avoid possible tool kick back. Use the reversing feature (lift table top pedal upwards) to back out of jam ups.

20. Hold the Bead Lifting Tool down until the upper bead is solidly above the rim. Continue rotating the wheel clockwise until the upper bead is completely demounted. (See Fig. 11.18 - 11.20)



Fig. 11.18



Fig. 11.19



Fig. 11.20

20. Liberally lubricate the lower bead again, if there was any difficulty lubricating the lower bead earlier. (See Fig. 11.21)



Fig. 11.21

21. Lift and hold the tire so it is positioned with the lower bead in the drop-center portion of the wheel. If the tire is large/wide or has become stuck on the lower part of the rim, the Bead Lifting Tool may be used to un-stick and raise the tire. (See Fig. 11.22)



Fig. 11.22



**DANGER!**  
The Bead Lifting Tool and demount head may encounter resistance or come under load at times during the mount and demount procedures. Keep one hand firmly on the tool to avoid possible tool kick back. Use the reversing feature (lift table top pedal upwards) to back out of jam ups.

22. Insert the smooth curved end of the Bead Lifting Tool over the “duckbill” end of Mount/ Demount Head and below the lower bead of the tire. Push the Bead Lifting Tool down toward the wheel to lift the tire bead up and over the “duckbill” side knob portion of the Mount/ Demount Head. Hold the Bead Lifting Tool in this position.  
(See Fig. 11.23 - 11.24)



23. Depress the Table Top Pedal to rotate the wheel.  
(See Fig. 11.25)

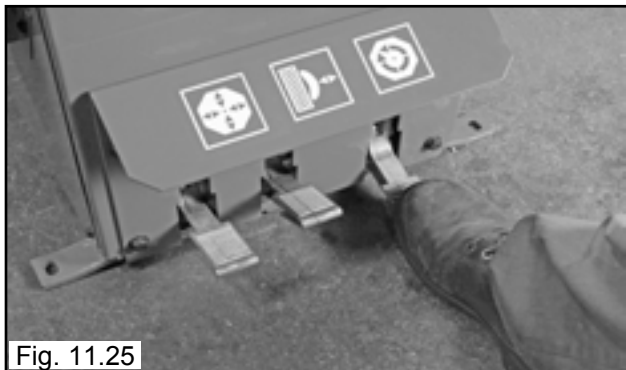

24. The Mount/ Demount Head will guide the bead up and over the edge of the wheel. Continue rotation until the lower bead is demounted. (See Fig. 11.26 - 11.28)



## SECTION 12

### CUSTOM AND SPECIAL WHEELS

If a custom wheel is damaged in dismantling, STOP, and avoid damaging the other wheels. Continue only when the cause is identified and corrected.



#### Alloy Wheels

Some manufacturers offer wheels with little or no drop center. These are not DOT approved. The tire or wheel - or both - can be damaged and the tire could explode under pressure, resulting in serious injury or death. If you attempt to mount/demount this type of wheel, use extreme caution. (See Fig. 12.1)

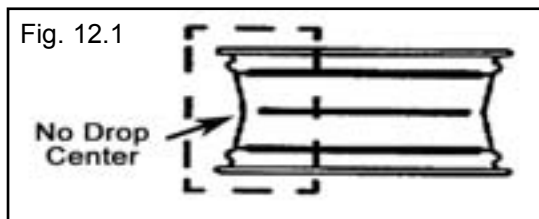

#### European Performance Wheels (Asymmetrical Hump)

Some European wheels have very large humps except near the valve hole. On these wheels, the beads should be loosened at the valve hole on both the upper and lower sides first.

#### Some Wheels with Tire Pressure Warning Sensors

Performance wheels on some vehicles have a pressure sensor strapped to the rim opposite the valve hole or mounted on the valve stem. On these wheels, the beads should be loosened at the valve hole on both upper and lower sides first. (See Fig. 12.2)

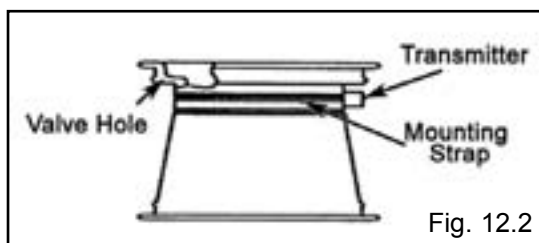

### DEMOUNTING TUBE TYPE TIRES

1. After both tire beads are loosened, lubricate the beads and rim liberally.

2. Position the demount head and bead lifting tool as described earlier paying careful attention not to pinch the tube. Depress the table top pedal and rotate only a short distance at a time. This allows you to stop the process should you suspect the tube is getting pinched.

3. After upper bead is demounted, remove tube and demount lower bead.

#### NOTE:

Table top rotation can be stopped at any time by removing your foot from the rotation pedal. Normal table top rotation for demounting is clockwise. Depress the table top pedal to rotate this direction. To rotate the table top counterclockwise, lift the pedal up with your toe.

#### FOR TUBE-TYPE TIRES

With tube-type tires, demount the upper bead and remove the tube before de-mounting the lower bead.

## SECTION 13

### MOUNTING

This information must be read and followed carefully to prevent accidents and injuries during mounting.



#### WARNING!

Check tire and wheel carefully before mounting. Make sure the tire bead diameter and wheel diameter match exactly. Consult the Rubber Manufacturer's Association for approved rim widths for tire sizes.



#### WARNING!

Attempts to force a bead seat on mis-matched tires and wheels can cause the tire to violently explode, causing serious personal injury or death to operator and/or bystanders.



#### WARNING!

Never mount a tire and wheel handed to you by anyone without checking both tire and wheel for damage and compatibility. Be extra cautious of persons without knowledge of tire service. Keep bystanders out of service area.



#### WARNING!

Never mount a damaged tire. Never mount a tire on a rusty or damaged wheel. Damaged tires and/or wheels may explode.

**⚠ WARNING**

**WARNING!**  
If you damage the tire bead during mounting, **STOP!** Remove the tire and mark it as damaged. Do not mount a damaged tire.

1. Inspect the wheel closely for damage. Clean the wheel and remove any light corrosion or rubber residue. Do not attempt to service heavily corroded wheels. (See Fig. 13.1)



2. Inspect tire for damage, paying close attention to the beads. Verify size match between tire and wheel. (See Fig. 13.2)



3. Lubricate both tire beads liberally with tire manufacturer's approved lubricant. (See Fig. 13.3)

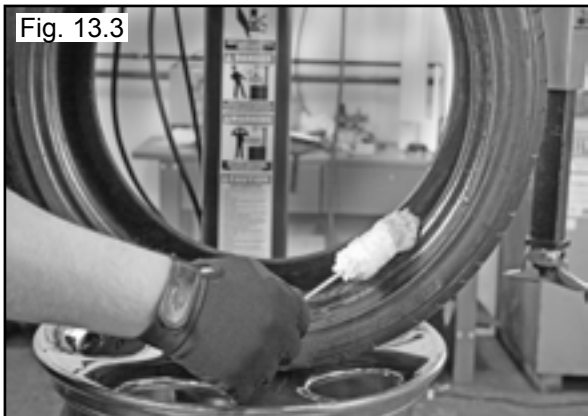

**⚠ WARNING**

**WARNING!**  
**THE RIM AND BEAD MUST BE LIBERALLY LUBRICATED. FAILURE TO USE AN ADEQUATE LUBRICANT CAN LEAD TO THE BEAD BINDING ON THE RIM AND LEAD TO DAMAGE TO THE MOTOR AND OR VOID THE WARRANTY.**

4. Place tire over wheel and move Tower and Mount/ Demount Head into position as described earlier. Position tire so that the lower bead is above the left side of the Mount/ Demount Head and below the right front knob. (See Fig. 13.4)

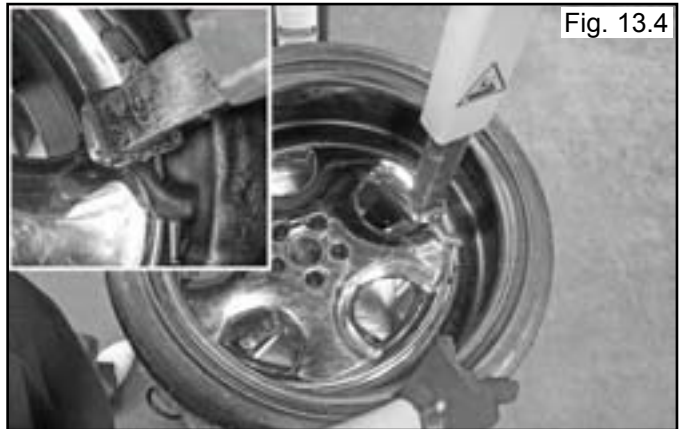

5. Manually force the tire down into the drop center of the wheel directly across from the Mount/ Demount Head to reduce the tensional force on the bead. Depress the Table Top Pedal and rotate the wheel to mount the lower bead. Rotate the Table Top until the lower bead is fully mounted. (See Fig. 13.5 - 13.6)



6. For the top bead, rotate the Table Top until the valve stem is directly across from the Mount/ Demount Head. Lift the upper bead above the side of the Mount/ Demount Head and below the “duckbill” side. (See Fig. 13.7 - 13.8)



Fig. 13.7



Fig. 13.8

8 . With



**DANGER!**

The Bead Lifting Tool and demount head may encounter resistance or come under load at times during the mount and demount procedures. Keep one hand firmly on the tool to avoid possible tool kick back. Use the reversing feature (lift table top pedal upwards) to back out of jam ups.

the Bead Lifting Tool, press down on the tire to hold the upper bead in the drop center. (See Fig. 13.9)

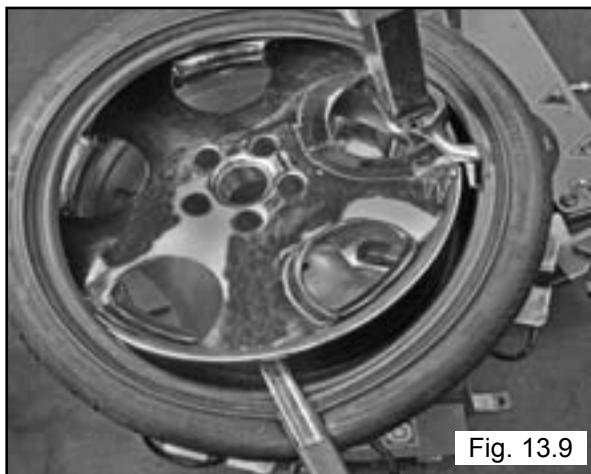

Fig. 13.9

**NOTE:**

Low Profile / stiff sidewall Tires may require use of a second Bead Lifting Tool.



**Do not force the tire onto the rim. Bead damage could result making the tire unsafe and/or creating the risk of injury.**

9. Stand firmly in place and be prepared to hold the Bead Lifting Tool down as the tire/ Turntable rotates. Depress the Table Top Pedal and rotate the tire until the bead is mounted. (See Fig. 13.10 - 13.13)

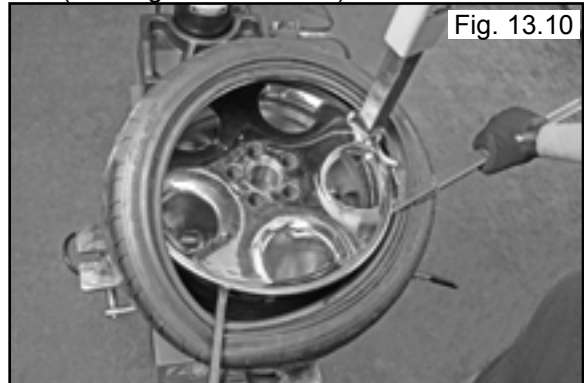

Fig. 13.10

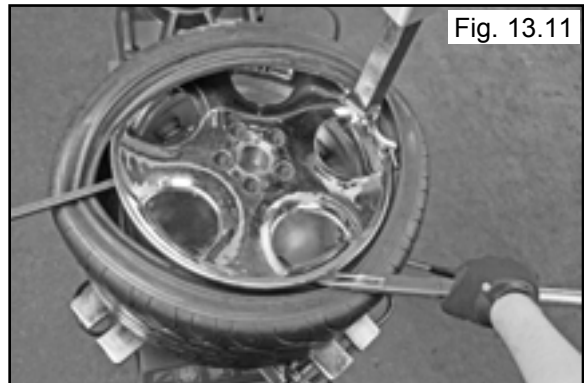

Fig. 13.11

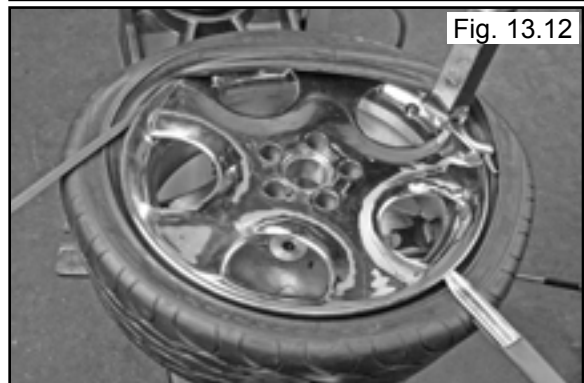

Fig. 13.12

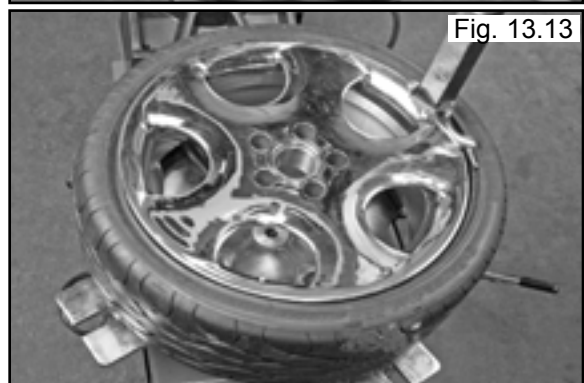

Fig. 13.13



## SECTION 14

### MOUNTING TUBE TYPE TIRES

1. Lubricate the beads and rim liberally.
2. Position the Mount/ Demount Head and bead lifting tool as described earlier. Mount the bottom bead first.
3. Round out the tube with a small amount of air. Avoid pinching or forcing the tube. Apply rubber lubricant to the tube.
4. Insert the tube into the tire paying careful attention not to pinch the tube.
5. Depress the Table Top Pedal and rotate only a short distance at a time. This allows you to stop the process should you suspect the tube is getting pinched.
6. Mount the top bead.

## SECTION 15

### INFLATION INSTRUCTIONS

Tire inflation is performed in Three Stages: Bead Seal, Bead Seat, and Inflation. Read the explanation of each step and understand them thoroughly before proceeding.



#### DANGER!

Check inflation gauge for proper operation. Accurate pressure readings are important to safe tire inflation. Refer to the Operating Maintenance section of this manual for instructions. If the rim has been clamped from the outside for tire mounting, release the clamps once bead seal is obtained, lift the tire, and move the clamps to the center of the table top.



#### WARNING!

Tire failure under pressure is hazardous. This tire changer is not intended to be a safety device to contain exploding tires, tubes, wheels, or bead sealing equipment. Inspect tire and wheel carefully for match, wear, or defects before mounting. Always use approved tire bead lubricant during mounting and inflation. The Inflation Gun controls the flow of air through the Inflation Hose.



#### DANGER!

The clip-on air chuck on the end of the Inflation Hose and all inflation related components should be checked weekly for proper operation. DO NOT USE this machine for tire inflation if any parts are damaged or appear not in proper working order.

#### INFLATION GUN OPERATION

The Inflation Gun located checks air pressure in the tire; controls the flow of air through the Inflation Hose and releases air pressure in the tire. (See Fig. 15.1)

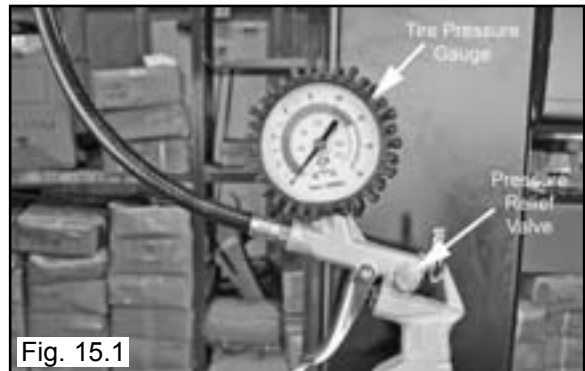

Fig. 15.1

**Tire Pressure** – With the Inflation Hose attached to the tire valve the air gauge will register the air pressure in the tire.

**Tire Inflation** – With the Inflation Hose attached to the tire valve, pulling the trigger allows line pressure to flow through the valve and into the tire for inflation. (See Fig. 15.2)

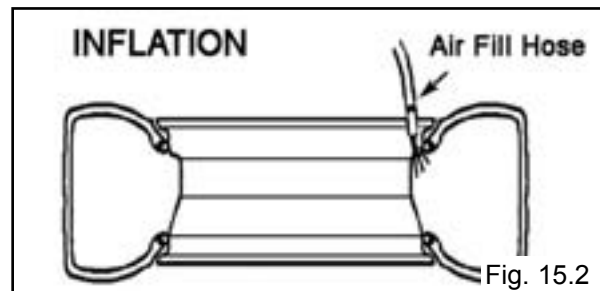

Fig. 15.2

**Pressure Release** – With the Inflation Hose attached to the tire, pressing the Pressure Release Valve will release air pressure from the tire.

## SECTION 16

### TIRE INFLATION

#### STAGES OF INFLATION

Review the following descriptions and diagrams carefully. Refer to them as necessary during, bead sealing, bead seating, and inflation to verify that you are proceeding properly and safely.



This machine is not intended to be a restraining device for exploding tires, tubes, or rims.

**KEEP HANDS AND BODY CLEAR** at all times and as far back as possible during inflation.

**DO NOT** lean over the tire while inflating.

An exploding tire, rim or other wheel component can cause death to operator and/or bystander.

**REMAIN CLEAR AT ALL TIMES.**

#### STAGE ONE / BEAD SEALING

1. Position valve stem in front of operator and connect the Inflation Hose. (See Fig. 16.1)

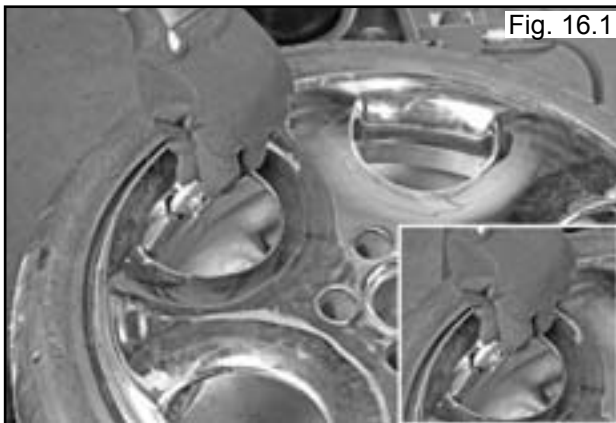

2. Hold tire up against upper edge of the wheel. Be sure tire's top bead is over the bottom of the valve stem. (See Fig. 16.2)



3. Pull the Inflation Trigger and hold about to begin air flow through tire valve, the blast of air will expand tire and seal the beads. (See Fig. 16.3)

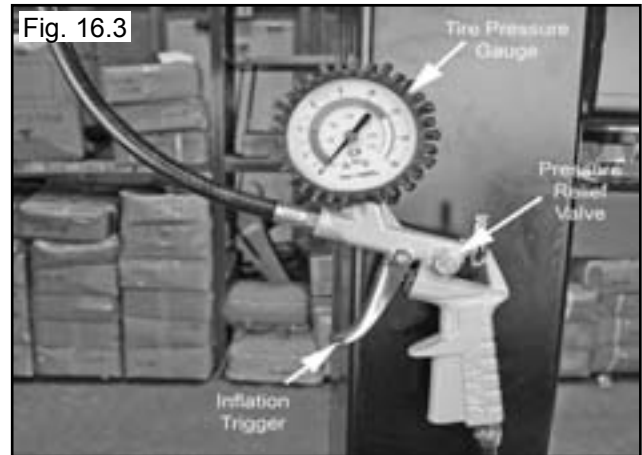

4. Release the Inflation Trigger. Verify that both beads are completely sealed to the wheel. Repeat these steps if beads have not sealed. If tire and wheel are properly lubricated and operator cannot achieve bead seal after a few attempts, the valve core may be removed from the valve stem to allow more air flow into the tire to assist with bead seal. After bead seal is achieved, remove the chuck and reinstall the valve core.

#### STAGE TWO / BEAD SEATING

Bead seating usually occurs on the long tapered side of the wheel first and the shorter side last. Bead seating will usually require at least 7 PSI in the tire. 40 PSI is the maximum safe pressure at this stage regardless of tire operating pressure. Most European import cars and many aftermarket alloy wheels are very tight and can be difficult to bead seat. Also note that asymmetrical hump and run-flat tires are extremely difficult to bead seat. Follow tire manufacturer's recommended procedure for bead seating.



#### **WARNING!**

**Operator should keep hands, arms, and entire body away from the tire during the following bead seat and inflation procedures. Do not stand over tire, as personal injury could result from inflating tire. Avoid distraction during inflation. Check tire pressure frequently to avoid over inflation. Excessive pressure can cause tires to explode, causing serious injury or death to operator or bystander.**



**KEEP HANDS AND FINGERS CLEAR.  
KEEP ENTIRE BODY AWAY FROM THE TIRE**



**DANGER!**

**NEVER** increase tire pressure to exceed 40 PSI when attempting Bead Seat. If operator is unable to obtain Bead Seat, something is wrong. Deflate tire completely, inspect tire and wheel, correct any problems found, re-lubricate both tire beads, and reattempt Bead Seal and Seat procedures. Follow and follow all safety instructions in this manual and on machine.

1. Once tire pressure is indicated on the air gauge, continue to inject air into the tire in short intervals. Check the pressure frequently. Stand back during bead seat. Keep hands, arms, and entire body away from tire during this procedure. Tire beads should move outward and “pop” into their bead seat position as pressure inside the tire increases. If this does not happen, a problem exists. Investigate carefully. (See Fig. 16.4)



2. Release air pressure from the tire by pressing the Manual Release Valve Button. NOTE: The Inflation Hose must be attached to the valve stem during this procedure. (See Fig. 16.5)

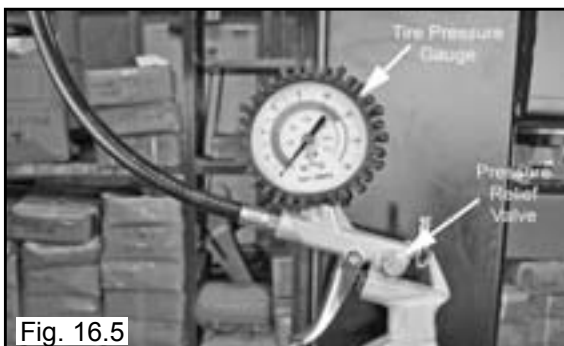

**STAGE THREE / TIRE INFLATION**



**WARNING!**

Check tire pressure frequently. Never exceed 40 PSI while seating beads. Once seated, never exceed tire manufacturer’s recommended air pressure. Tires can explode, especially if they are inflated beyond their limits. At all pressure levels when inflating through the valve stem, keep hands, arms, and entire body away from inflating tire.

An exploding tire, wheel, or bead sealing equipment may propel upward and outward with sufficient force to cause serious injury or death to operator or bystander.

**MIS-MATCHED TIRES AND WHEELS**

Never attempt to mount and inflate mis-matched tires and wheels. Mis-matched tire and wheel combinations can explode, causing personal injury or death to operator and bystanders. For safety, do not attempt to mount and inflate mis-matched tires and wheels.



**IMPORTANT!**

When inflating tires that require more than 60 PSI, always use a safety cage and air hose with a clip-on air chuck and in-line valve. The hose must have enough length between the chuck and the operation/in-line valve to allow the operator to stand outside the trajectory.





1. Make sure both beads are seated. When both beads are seated, the tire is ready for inflation.
2. Replace the valve core if it was removed.
3. Depress the inflation Trigger Pedal to inflate the tire.  
**DO NOT STAND OVER TIRE DURING INFLATION.**
4. Do not inflate the tire above the manufacturer's recommended pressure as stamped on the tire sidewall. The typical inflation pressure for automobile tires is between 24 and 45 PSI. Light truck inflation pressure typically covers a wider range. Release air pressure from the tire by pressing the manual release valve button.

## SECTION 17

### MAINTENANCE INSTRUCTIONS



#### WARNING!

- ◆ Before making any inspection, adjustment, or repair, disconnect the power source and or air supply and block out all moving parts to prevent injury.
- ◆ Keep the machine and the immediate work area clean. Do not use compressed air to remove dirt and debris from the machine. Foreign material may be propelled into the air and into operator or bystander causing personal injury.
- ◆ Wear protective clothing and use eye protection when making any adjustments or repairs to the machine.

Read and follow all the maintenance instructions provided in this manual to keep the machine in good operating condition. Regular inspections and proper maintenance are essential to preventing accidents and injuries. These instructions will help you service the unit. Instructions are for a person with some mechanical ability and training. No attempt has been made to describe all basic steps like how to loosen or tighten fasteners. Basic procedures such as cycling systems and checking operation of the equipment are not fully described. Do not attempt to perform work beyond your ability or at which you have no experience. If you need assistance, call an authorized service center or contact the factory.

#### DAILY

- ◆ Check the tire pressure gauge function daily, and check the accuracy monthly. Use a pressurized tire and a high quality stick-type pressure gauge. If the gauge is defective, replace it immediately.
- ◆ Make sure all fasteners are securely tightened and all guards and covers are in place.
- ◆ Check for worn, damaged or missing parts including grips and protective covers. Replace them before allowing the unit to be used.
- ◆ On a daily basis, inspect the unit and check to be certain that all systems are operating normally. Follow detailed inspection and testing procedures as specified for various components at regular intervals.

## MONTHLY

- ◆ Lubricate the Swing Arm Pivot Pin. (See Fig. 17.1)

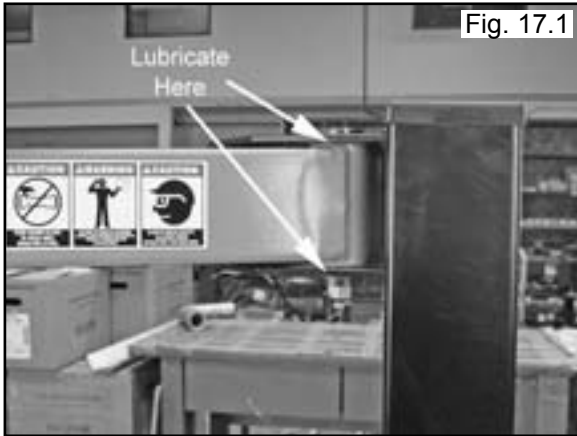

- ◆ Check adjustment of the mount/demount head monthly.
- ◆ Check the condition and adjustment of the turntable drive belt.
- ◆ The table top, clamps, steel mount/demount head, and other working surfaces should be cleaned with a vaporizing solvent every month.
- ◆ Replace any damaged or missing safety decal's. They are available from the factory.

### Mount/Demount Tool Head Adjustment

To adjust tool head lift, Remove Plastic Cover and adjust locking nut up or down until lift clearance is 1/8" to 3/16". Recheck clearance. (See Fig. 17.2)

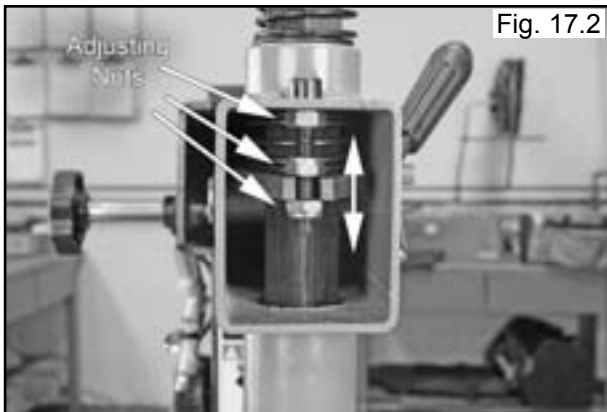

### Mount/Demount Head Cleaning

Clean dirt and debris from the mount/demount tool roller with small screw driver or pick. Lubricate with light penetrating oil. (See Fig. 17.3)



### Air Drier /Oiler Maintenance



**IMPORTANT!**  
Failure to maintain the Water Separator/ Air Oil regulator in proper condition may void warranty.  
Drain water out of the system regularly and keep the Oil reservoir filled.

Check oil and water levels regularly, and perform these maintenance items weekly.

- ◆ Observe the oil and water level on the water separator/ filter unit. (See Fig. 17.4)

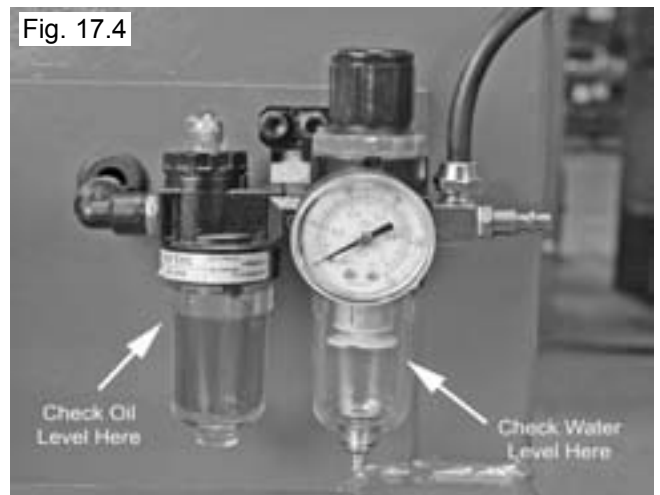

- ◆ If water is observed, drain by pushing up on the Drain Valve at the bottom of the reservoir. (See Fig. 17.5)

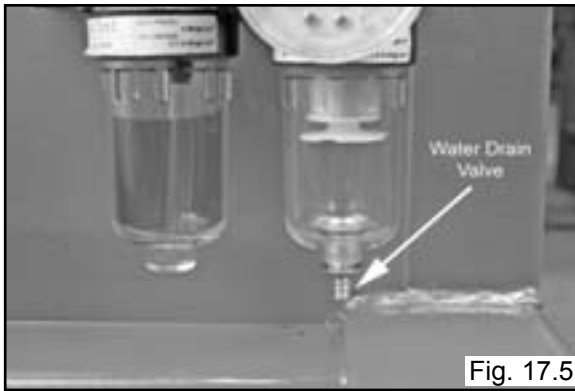

## Turntable Drive Belt Inspection / Adjustment.



**DANGER!** The motor on this machine contains high voltage. Disconnect power at the receptacle before performing any electrical repairs. Secure plug so that it cannot be accidentally plugged in during service.

1. Remove the Side Panel. (See Fig. 17.12)

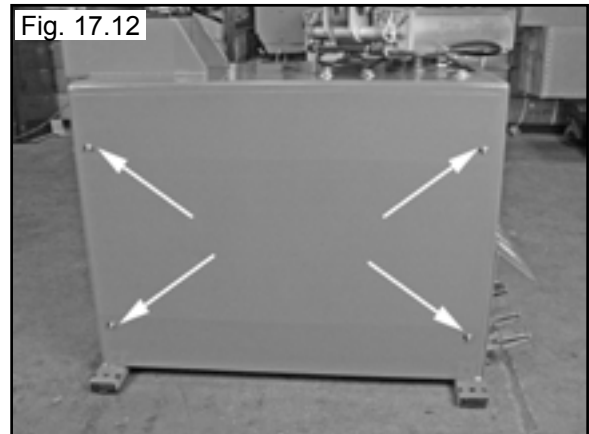

- ◆ Disconnect air supply to machine.
- ◆ Add oil to the lubricator if the fluid level is below the middle of the oil reservoir. Unscrew the Oil Reservoir, add SAE 10W non-detergent oil or an air tool oil if necessary.

### NOTE:

**This adjustment will require two persons to perform.**

1. With the Air source connected, depress the Bead Breaker Pedal to operate the Bead Breaker.
2. Observe the site glass and adjust the oil flow of the oiler by turning the Oiler Adjustment Knob so that 2-3 drops of oil drip through the site glass for each operation of the Bead Breaker Pedal. (See Fig 17.6)

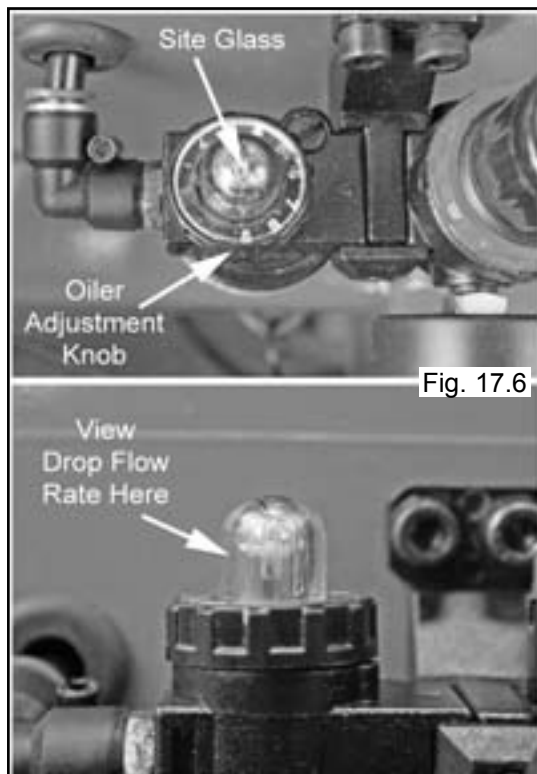

(Either reservoir may be removed for cleaning by turning the reservoir counter-clockwise and pulling down.)

3. Reconnect the air supply when service/adjustments are complete.

2. Loosen the four Motor mounting / adjusting bolts and nuts. (See Fig. 17.13)

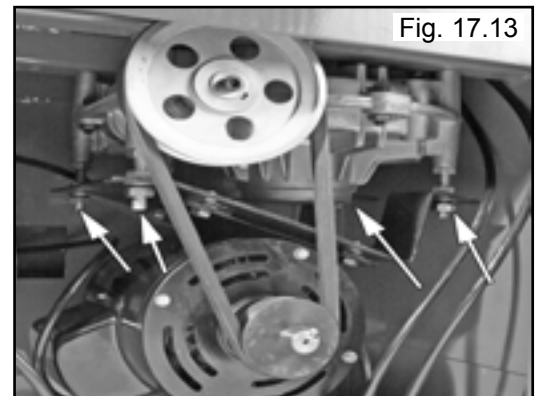

3. Inspect the Drive Belt for cracking and wear and replace as necessary. Adjust the Belt deflection to 3/8" - 1/2". (See Fig. 17.14)

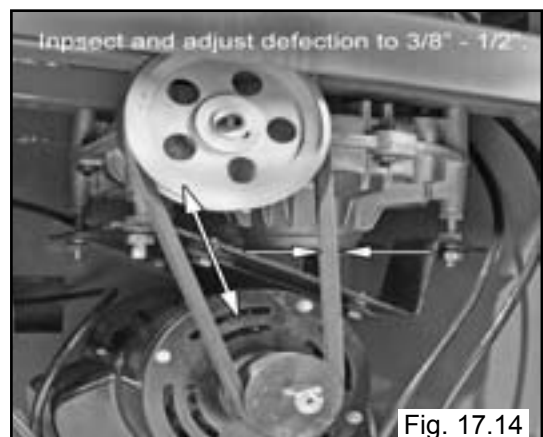

## Transmission Inspection / Lubrication



**DANGER!** The motor on this machine contains high voltage. Disconnect power at the receptacle before performing any electrical / repairs. Secure plug so that it cannot be accidentally plugged in during service.

1. Rotate the Turntable so that the Transmission Fill Plug is visible. (See Fig. 17.8)

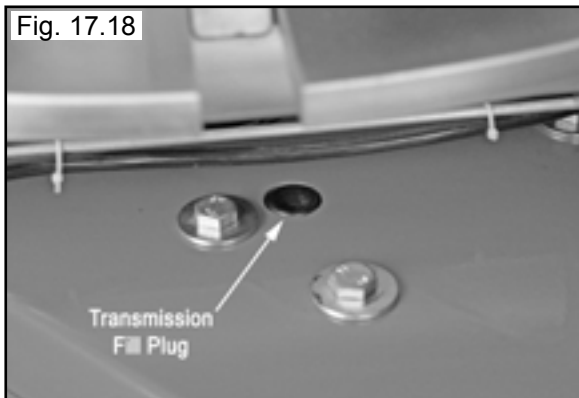

2. Remove the Fill plug.
3. Put a flexible wire into the Transmission Oil Fill Hole until the wire hits the bottom of the reservoir. (See Fig. 17.19)

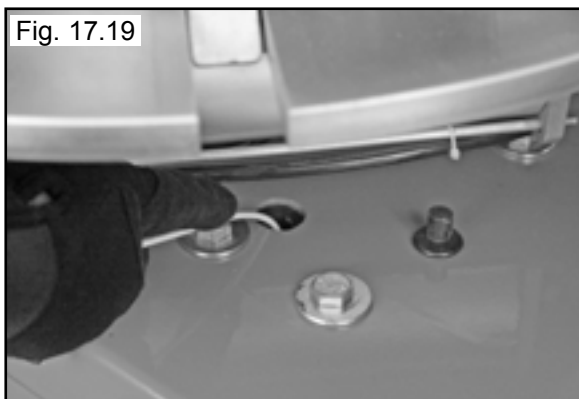

4. Remove the wire and check the level of the Transmission fluid. The oil level should be no more than 1" (25 mm) high on the wire.

### NOTE:



**Filling Oil Level higher will result in leakage of the transmission seals.**

 <h2>CAUTION</h2>	 <h2>WARNING</h2>	 <h2>CAUTION</h2>
		
<p><b>KEEP HANDS CLEAR OF BEAD AREA WHEN INFLATING.</b></p>	<p><b>BE SURE TO READ ALL WARNING LABELS AND INSTRUCTION MANUAL PRIOR TO OPERATION OF THIS MACHINE</b></p>	<p><b>ALWAYS WEAR SAFETY GLASSES WHEN OPERATING THIS MACHINE.</b></p>

 **WARNING**



**KEEP HANDS CLEAR OF ALL PINCH POINTS**

 **DANGER**



**STAND CLEAR WHILE INFLATING TIRE. TIRE OR WHEEL FAILURE UNDER PRESSURE MAY CAUSE SERIOUS INJURY OR DEATH.**

 **WARNING**



**DO NOT WEAR LOOSE CLOTHING, LONG HAIR OR JEWELRY. MOVING PARTS CAN SNAG AND PULL**

 **CAUTION**  
*READ FIRST*

- ✓ Be sure to **READ ALL WARNING LABELS** and instruction manual prior to operation of this machine. Failure to comply with proper safety instructions may lead to serious harm or even death of operator and/or bystanders.
- ✓ Improper operation of this machine may cause damage to machine or cause personal harm or injury.
- ✓ **ALWAYS** wear safety goggles when operating this machine.
- ✓ **KEEP HANDS CLEAR** of all pinch points.
- ✓ Check machine for damaged parts prior to operation. **DO NOT USE MACHINE** if any component is broken or damaged.
- ✓ **NEVER EXCEED** the factory recommended air pressure of tire. Over inflating the tire beyond the manufacturer's recommendation can cause tire burst or explosion.
- ✓ Operators should inspect all tires and rims for possible defects prior to mounting.
- ✓ **ALWAYS INSPECT TIRES BEFORE MOUNTING.** Defective or damaged tires may burst or explode when inflating and may lead to serious harm or injury.
- ✓ **ALWAYS MAKE SURE TIRE SIZE MATCHES RIM SIZE** prior to mounting. Mounting tires on defective or improper rims can cause tire burst or explosion and may lead to serious harm or injury.
- ✓ This machine is not intended to be a restraining device for exploding tires, tubes, or rims. All operators should take proper precaution to implement safety and to avoid personal injury or harm.
- ✓ **DO NOT** lean over the tire while inflating. **KEEP HANDS AND BODY CLEAR** at all times and as far back as possible during inflation. An exploding tire, rim, or component thereof can cause injury or death to operator and/or bystanders. **REMAIN CLEAR AT ALL TIMES.**
- ✓ To inflate tires, use short bursts while carefully monitoring the pressure, tire, rim, and bead.
- ✓ While seating beads **NEVER EXCEED 40 p.s.i.** If bead does not seat at 40 p.s.i., immediately relieve pressure and check for mismatch of tire, damaged bead and/or other cause.
- ✓ **ALWAYS USE** good quality tire lubricant when servicing tires.

**Always Think Safety!**





# R715 TIRE CHANGER

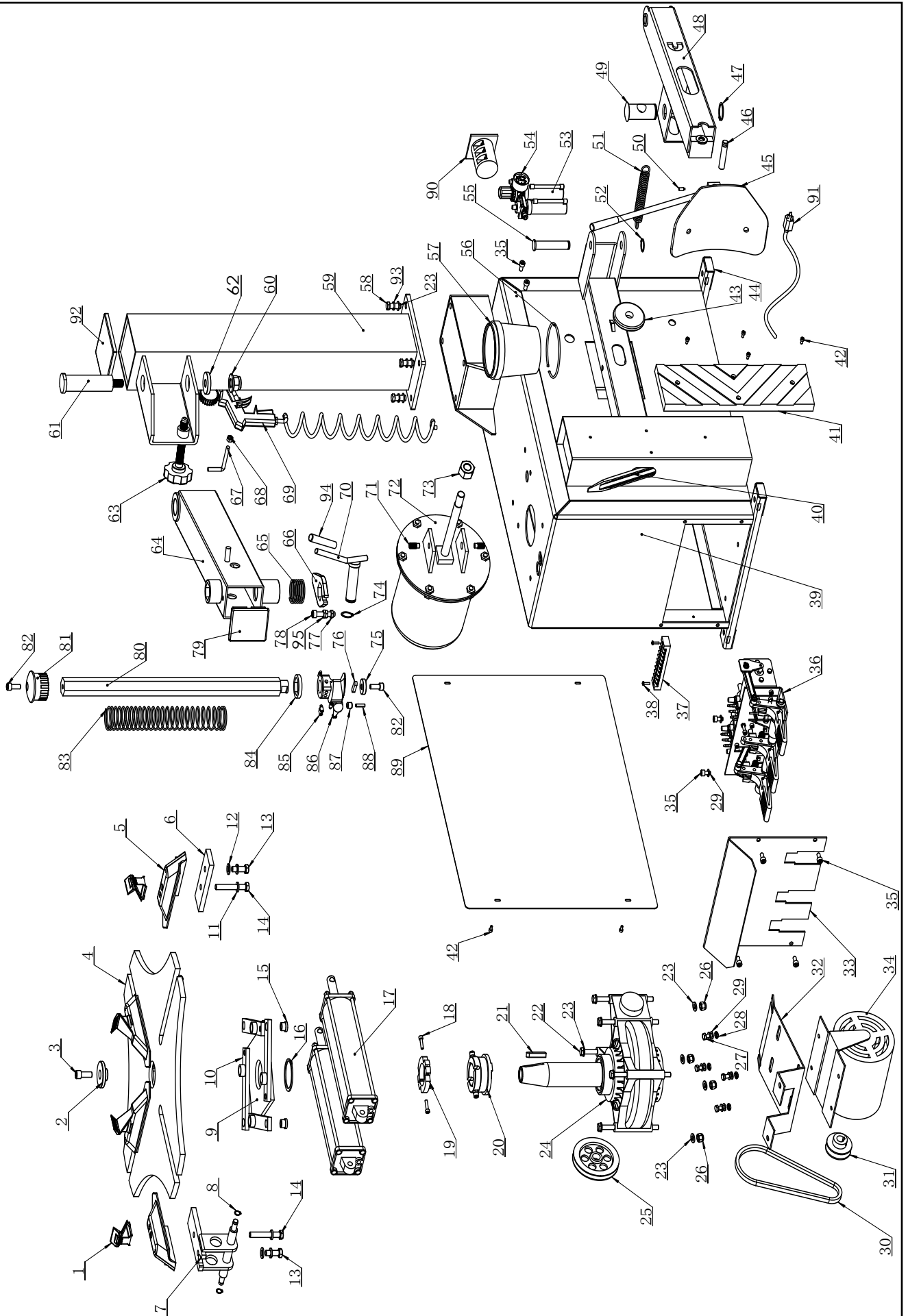

Ref	Product Description	Qty
1	Jaw Clamp	4
2	Turn Table Cap	1
3	M12 x 30 bolt	1
4	Turntable	1
5	Slide	4
6	Sliding Plate	2
7	Cylinder Bracket	2
8	Snap ring 12	4
9	Square Turntable	1
10	Jaw Clamp Linkage	4
11	Lock washer 12	8
12	Flat washer 12	8
13	Bolt M12 x 35	4
14	Bolt M12 x 75	4
15	Spacer Bushing	4
16	Snap ring 65	1
17	Jaw Clamp Cylinder	2
18	Nut M6 x 25	2
19	Clamp Ring	2
20	Rotary Joint Block	1
21	Key	1
22	Bolt M10 x 100	6
23	Flat washer 10	14
24	Transmission Assy	1
25	Transmission Pulley	1
26	Nut M10	12
27	Bolt M8 x 20	4
28	Nut M8	4
29	Flat Washer 8	10
30	Belt	1
31	Motor Pulley	1
32	Motor mount bracket	1
33	Pedal cover	1
34	Motor	1
35	Bolt M8 x 16	8
36	Foot Pedal Assembly	1
37	Terminal block	1
38	Screw M4 x 16	2
39	Cabinet	1
40	Tire tool	1
41	Large rubber Pad	1
42	Bolt M5 x 10	10
43	Bead Breaker Cylinder Shaft Pad	1
44	Tire Changer Foot Pad	4
45	Bead breaker Blade	1
46	Bolt	1
47	Snap ring 35	1
48	Bead breaker Arm	1

Ref	Product Description	Qty
49	Bead Breaker Cylinder Bracket	1
50	Bolt M6 x 16	1
51	Bead Breaker Spring	1
52	Snap ring 25	1
53	Water separate/Oiler	2
54	Pressure gauge	2
55	Bolt	1
56	Soap Bucket Bracket	1
57	Soap Bucket	1
58	Bolt M10 x 30	4
59	Tower	1
60	Nut M20	1
61	Swing arm pivot pin	1
62	Washer	1
63	Swing Arm Adjustment Bolt	1
64	Swing Arm	1
65	Spring	1
66	Locking Plate	1
67	Inflation Gun Storage Hook	1
68	Nut M8	1
69	Inflation Gun	1
70	Locking Lever	1
71	Cylinder Mounting Pin	2
72	Bead Breaker Cylinder	1
73	Nut M20	1
74	Snap Ring 25	1
75	Flat Washer	1
76	Mount-demount Head Plastic Insert	1
77	Nut M10	2
78	Bolt M10 x 50	1
79	Swing Arm Front Cover	1
80	Vertical Shaft	1
81	Cap	1
82	Bolt M10 x 25	2
83	Vertical Shaft Spring	1
84	Spacer	1
85	Set screw M10 x 16	4
86	Mount-demount Head	1
87	Roller	1
88	Roll Pin 6 x 24	1
89	Side cover	1
90	110/220 switch	1
91	Power cord	1
92	Tank Top Cover	1
93	Lock Washer 10	4
94	Plastic Handle	1
95	Nut M10	1



*The best automotive service equipment on the planet.*

**For Parts Or Service  
Contact:**

**BendPak Inc. / Ranger Products  
1645 Lemonwood Dr.  
Santa Paula, CA. 93060**

**Tel: 1-805-933-9970  
Toll Free: 1-800-253-2363  
Fax: 1-805-933-9160**

**[www.bendpak.com](http://www.bendpak.com)  
[www.rangerproducts.com](http://www.rangerproducts.com)**

PN# 5900172

