

! WARNING

PLEASE READ THE ENTIRE CONTENTS OF THIS MANUAL PRIOR TO INSTALLATION AND OPERATION. BY PROCEEDING YOU AGREE THAT YOU FULLY UNDERSTAND AND COMPREHEND THE FULL CONTENTS OF THIS MANUAL. FORWARD THIS MANUAL TO ALL OPERATORS. FAILURE TO OPERATE THIS EQUIPMENT AS DIRECTED MAY CAUSE INJURY OR DEATH.

MAN REV D 05-27-2015

P/N 5900176

INSTALLATION AND OPERATION MANUAL

Portable Column Lifting System

**Model:
PCL-18**



READ FIRST



Do not operate this machine until you read and understand all the dangers, warnings and cautions in this manual.

Keep this operation manual near the machine at all times. Make sure that ALL USERS read this manual.

IMPORTANT
Reference ANSI/ALI ALIS, Safety Requirements for Installation and Service of Automotive Lifts before installing lift.

SHIPPING DAMAGE CLAIMS

When this equipment is shipped, concerns for material damaged in shipment must be noted by the purchaser on the delivery receipt at the time shipment is received to ensure proper handling by the shipper.

BE SAFE

Your new lift was designed and built with safety in mind. However, your overall safety can be increased by proper training and thoughtful operation on the part of the operator. DO NOT operate or repair this equipment without reading this manual and the important safety instructions shown inside.





1645 Lemonwood Dr.
Santa Paula, CA. 93060, USA
Toll Free 1-800-253-2363
Tel: 1-805-933-9970
Fax: 1-805-933-9160
www.bendpak.com

PCL-18 Portable Column Lift

This instruction manual has been prepared especially for you.
Your new lift is the product of over 40 years of continuous research, testing and development;
it is the most technically advanced lift on the market today.

READ THIS ENTIRE MANUAL BEFORE INSTALLATION & OPERATION BEGINS

RECORD HERE THE LIFT AND
POWER UNIT INFORMATION WHICH IS
LOCATED ON THE SERIAL NUMBER
DATA PLATES ON THE LIFT AND
ON THE POWER UNIT

   1645 Lemonwood Dr., Santa Paula, CA 93060 USA Tel: 1-805-933-9970 Fax: 1-805-933-9160 www.bendpak.com		
Model No.	Lifting Capacity	Serial No.
Date of Mfg.	Power Unit No.	Voltage / Amperage

Power Unit Model # _____
Power Unit Date Of Mfg. _____
Power Unit Serial # _____
Max Operating Pressure 2,060 PSI

This information is required when
calling for parts or warranty issues.

**OUR LIFTS ARE SHIPPED WITHOUT OIL.
ADD OIL TO POWER UNIT TANK BEFORE USE.**

PRODUCT WARRANTY

Our comprehensive product warranty means more than a commitment to you; it's also a commitment to the value of your new BendPak lift. For full warranty details contact your nearest BendPak dealer or visit:

<http://www.bendpak.com/support/warranty/>

**WARRANTY IS NOT VALID UNLESS
WARRANTY CARD IS RETURNED**

IMPORTANT NOTICE

Do not attempt to install this lift if you have never been trained on basic automotive lift installation procedures. Never attempt to lift components without proper lifting tools such as forklift or cranes. Stay clear of any moving parts that can fall and cause injury. These instructions must be followed to ensure proper installation and operation of your lift. Failure to comply with these instructions can result in serious bodily harm and void product warranty. Manufacturer will assume no liability for loss or damage of any kind, expressed or implied, resulting from improper installation or use of this product.

PLEASE READ ENTIRE MANUAL PRIOR TO INSTALLATION.

DEFINITIONS OF HAZARD LEVELS

Identify the hazard levels used in this manual with the following definitions and signal words:



Watch for this symbol. It means immediate hazards which will result in severe personal injury or death.



Beware of this symbol. It means hazards or unsafe practices could result in severe personal injury or death.



Take note of this symbol. It means hazards or unsafe practices which may result in minor personal injury, product or property damage.

OWNER'S RESPONSIBILITY

To maintain the lift and user safety, the owner's responsibility to read and follow these instructions:

- ◆ Follow all installation and operation instructions.
- ◆ Make sure installation conforms to all applicable Local, State, and Federal Codes, Rules, and Regulations; such as State and Federal OSHA Regulations and Electrical Codes.
- ◆ Carefully check the lift for correct initial function.
- ◆ Read and follow the safety instructions. Keep them readily available for machine operators.
- ◆ Make certain all operators are properly trained, know how to safely and correctly operate the unit, and are properly supervised.
- ◆ Allow unit operation only with all parts in place and operating safely.
- ◆ Carefully inspect the unit on a regular basis and perform all maintenance as required.
- ◆ Service and maintain the unit only with authorized or approved replacement parts.
- ◆ Keep all instructions permanently with the unit and all decals on the unit clean and visible.

BEFORE YOU BEGIN

NOTIFY THE CARRIER AT ONCE if any hidden loss or damage is discovered after receipt and request the carrier to make an inspection. If the carrier will not do so, prepare a signed statement to the effect that you have notified the carrier (on a specific date) and that the carrier has failed to comply with your request.

IT IS DIFFICULT TO COLLECT FOR LOSS OR DAMAGE AFTER YOU HAVE GIVEN THE CARRIER A CLEAR RECEIPT. Support claim with copies of the Bill of Lading, freight bill, invoice, and photographs, if available. BendPak's willingness to assist in helping you process your claim does not make BendPak responsible for collection of claims or replacement of lost or damaged materials.

TABLE OF CONTENTS

- Warranty / Serial Number Information2
- Definitions of Hazard Levels 3
- Owner’s Responsibility3
- Before You Begin. 3
- Installer/Operator Agreement/ Protective Equipment. 5
- Safety / Warning Instructions 6
- Section 1 / Selecting Site7
- Section 2 / Floor Requirements7
- Concrete Specifications. 7
- Assembly View / Parts Inventory 8
- Section 3 / Layout / Specifications /Clearances 9-10
- Section 4 / Hydraulic Jacking System 11
- Section 5 / Electrical Connections12-15
- Section 6 / Communication Cable and Positioning16
- Section 7 / Control Panels 17-18
- Section 8 / Initial Start-up and PLC System Overview 19-20
- Section 9 / Testing Procedures 20-21
- Section 10 / Operation Instructions 22-25
- Maintenance 26
- Product Decals 27-31
- Safe Lift Operation 32-33
- Troubleshooting and Faults 34-40
- Installation Form 41
- Part Breakdowns 42-45
- Optional Equipment 46
- Maintenance Records 47

**INSTALLER / OPERATOR
PLEASE READ AND FULLY
UNDERSTAND. BY PROCEEDING
YOU AGREE TO THE FOLLOWING:**

- ◆ I have visually inspected the site where the lift is to be installed and verified the concrete to be in good condition and free of cracks or other defects. I understand that installing a lift on cracked or defective concrete could cause lift failure resulting in personal injury or death.
- ◆ I understand that a level floor is required for proper installation and level lifting.
- ◆ I understand that I am responsible if my floor is of questionable slope and that I will be responsible for all charges related to pouring a new level concrete slab if required.
- ◆ I will assume full responsibility for the concrete floor and condition thereof, now or later, where the above equipment model is to be installed. Failure to follow Danger, Warning, and Caution instructions may lead to serious personal injury or death to operator or bystander or damage to property.
- ◆ I understand that BendPak lifts are designed to be installed in indoor locations only. Failure to follow installation instructions may lead to serious personal injury or death to operator or bystander or damage to property or lift.

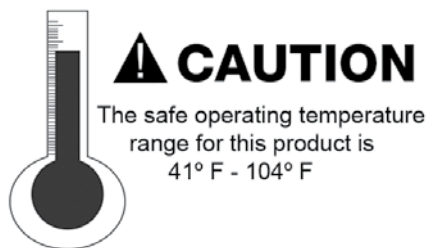

Failure to follow Danger, Warning, and Caution instructions may lead to serious personal injury or death to operator or bystander or damage to property.



Please read the entire manual prior to installation. Do not operate this machine until you have read and have understood all of the Danger, Warning and Caution alerts in this manual. For additional copies or further information, contact:

BendPak Inc.

1645 Lemonwood Dr.

Santa Paula, CA. 93060

1-805-933-9970

www.bendpak.com

**INSTALLER / OPERATOR
PROTECTIVE EQUIPMENT**

Personal protective equipment helps to make installation and operation safer; however, it does not take the place of safe operating practices. Always wear durable work clothing during any installation and/or service activity. Shop aprons or shop coats may also be worn, however loose-fitting clothing should be avoided.

Tight-fitting leather gloves are recommended to protect the technician's hands when handling parts. Sturdy leather steel-toe work shoes and oil resistant soles should be used by all service personnel to help prevent injury during typical installation and operation activities.



Eye protection is essential during installation and operation activities. Safety glasses with side shields, goggles, or face shields are acceptable. Back belts provide support during lifting activities and are also helpful in providing worker protection. Consideration should also be given to the use of hearing protection if service activity is performed in an enclosed area, or if noise levels are high.



THIS SYMBOL POINTS OUT IMPORTANT SAFETY INSTRUCTIONS WHICH IF NOT FOLLOWED COULD ENDANGER THE PERSONAL SAFETY AND/OR PROPERTY OR YOURSELF AND OTHERS AND CAN CAUSE PERSONAL INJURY OR DEATH. READ AND FOLLOW ALL INSTRUCTIONS IN THIS MANUAL BEFORE ATTEMPTING TO OPERATE THIS MACHINE.

1. Carefully remove the crating and packing materials.
CAUTION! Be careful when cutting steel banding material as items may become loose and fall causing personal harm or injury.

2. Check the voltage, phase and proper amperage requirements for the motor shown on the motor plate. Wiring should be performed by a certified electrician only.

IMPORTANT SAFETY INSTRUCTIONS

Read these safety instructions entirely

IMPORTANT NOTICE

Do not attempt to install this lift if you have never been trained on basic automotive lift installation procedures.

Never attempt to lift components without proper lifting tools such as forklift or cranes. Stay clear of any moving parts that can fall and cause injury.

1. READ and understand all instructions and all safety warnings before operating lift.
2. Care must be taken as burns can occur from touching hot components.
3. DO NOT operate equipment with a damaged cord or if the equipment has been dropped or damaged until it has been examined by a qualified service person.
4. DO NOT let a cord hang over the edge of the table, bench, or counter or come in contact with hot manifolds or moving fan blades.
5. If an extension cord is necessary, a cord with a current rating equal to or more than that of the equipment should be used. Cords rated for less current than the equipment may overheat. Care should be taken to arrange the cord so that it will not be tripped over or pulled.
6. ALWAYS unplug equipment from electrical outlet when not in use. Never use the cord to pull the plug from the outlet. Grasp plug and pull to disconnect.
7. Let equipment cool completely before putting away. Loop cord loosely around cable hook when storing.
8. DO NOT operate equipment in the vicinity of open containers of flammable liquids (gasoline) to reduce the risk of fire.
9. Adequate ventilation should be provided when working on operating internal combustion engines.
10. Keep hair, loose clothing, fingers, and all parts of body away from moving parts. Keep feet clear of lift when lowering. Avoid pinch points.
11. DANGER! To reduce the risk of electric shock, do not use on wet surfaces or expose to rain. The power unit used on this lift contains high voltage. Disconnect power at the receptacle or at the circuit breaker switch before performing any electrical repairs. Secure plug so that it cannot be accidentally plugged in during service. Or mark circuit breaker switch so that it cannot be accidentally switched on during service.



12. Use only as described in this manual. Use only manufacturer's recommended attachments.

13. ALWAYS WEAR SAFETY GLASSES. Everyday eyeglasses only have impact resistant lenses, they are not safety glasses.



14. CONSIDER WORK ENVIRONMENT. Keep work area clean. Cluttered work areas invite injuries. Keep areas well lit.

15. GUARD AGAINST ELECTRIC SHOCK. This lift must be grounded while in use to protect operator from electric shock. Never connect the green power cord wire to a live terminal. This is for ground only.

16. Only trained operators should operate this lift. All non-trained personnel should be kept away from the work area. Never let non-trained personnel come in contact with, or operate lift.

17. DO NOT override self-closing lift controls.

18. CLEAR AREA if vehicle is in danger of falling.

19. ALWAYS make sure the safeties are engaged before attempting to work on or near a vehicle.



21. WARNING! RISK OF EXPLOSION. This equipment has internal arcing or sparking parts which should not be exposed to flammable vapors. This machine should not be located in a recessed area or below floor level.

22. MAINTAIN WITH CARE. Keep lift clean for better and safer performance. Follow manual for proper lubrication and maintenance instructions. Keep control handles, buttons and displays dry, clean and free from grease and oil.

23. Check for damaged parts. Check for alignment of moving parts, breakage of parts or any condition that may affect operation of lift. Do not use lift if any component is broken or damaged.

24. NEVER remove safety related components from the lift. Do not use lift if safety related components are missing or damaged.

23. STAY ALERT. Use common sense and watch what you are doing. Remember, SAFETY FIRST.

SAVE THESE INSTRUCTIONS

IMPORTANT INSTRUCTIONS

These instructions must be followed to ensure proper installation and operation of your lift. Failure to comply with these instructions can result in serious bodily harm and void product warranty. Manufacturer will assume no liability for loss or damage of any kind, expressed or implied, resulting from improper installation or use of this product.
PLEASE READ ENTIRE MANUAL PRIOR TO INSTALLATION

SECTION 1 (SELECTING SITE)

Before installing your new lift, check the following.

1. **LIFT LOCATION:** Always use architectural plans when available. Check the layout dimension against the floor plan requirements, making sure that adequate space is available.
2. **OVERHEAD OBSTRUCTIONS:** The area where the lift will be located should be free of overhead obstructions such as heaters, building supports, electrical lines, etc.
3. **DEFECTIVE FLOOR:** Visually inspect the site where the lift is to be installed and check for cracked or defective concrete.
4. Lift is designed for **INDOOR INSTALLATION ONLY**. Always follow warnings illustrated on equipment labels.



- ◆ **DO NOT** install or use this lift on any asphalt surface or any surface other than concrete.
- ◆ **DO NOT** install or use this lift on expansion seams or on cracked or defective concrete.
- ◆ **DO NOT** install or use this lift on a second / elevated floor without first consulting building architect.
- ◆ **DO NOT** install or use this lift in extremely damp environments.

SECTION 2 (FLOOR REQUIREMENTS)



This lift must be installed on a solid level concrete floor with no more than 3-degrees of slope. Failure to do so could cause personal injury or death.

A level floor is suggested for proper use, installation and level lifting. If a floor is of questionable slope, consider a survey of the site and/or the possibility of pouring a new level concrete slab.

**OUR LIFTS ARE SHIPPED WITHOUT OIL.
ADD OIL TO POWER UNIT TANK BEFORE USE.**

LIFT MODEL	CONCRETE REQUIREMENTS
PCL-18	5" Min Thickness



ALL MODELS MUST BE INSTALLED ON CONCRETE ONLY CONFORMING TO THE MINIMUM REQUIREMENTS SHOWN ABOVE. NEW CONCRETE MUST BE ADEQUATELY CURED BY AT LEAST 28 DAYS MINIMUM.



When removing the lift from shipping angles, pay close attention as the columns can slide and can cause injury. Be careful when cutting steel banding material as items may become loose and fall causing personal harm or injury. Prior to removing the pallets make sure the posts are held securely by a fork lift or some other heavy lifting device.

PARTS INVENTORY

Be sure to take a complete inventory of parts prior to beginning installation.

Description	Qty
Column Assembly	4
Carriage Assembly	4
Fork Arm Weldment	8
Displacement Sensor Cover	4
Control Box Assembly	4
Motor Cover Assembly	4
Parts Box (Packing List Enclosed)	4
Hydraulic Jack	4
Hydraulic Power Unit	4

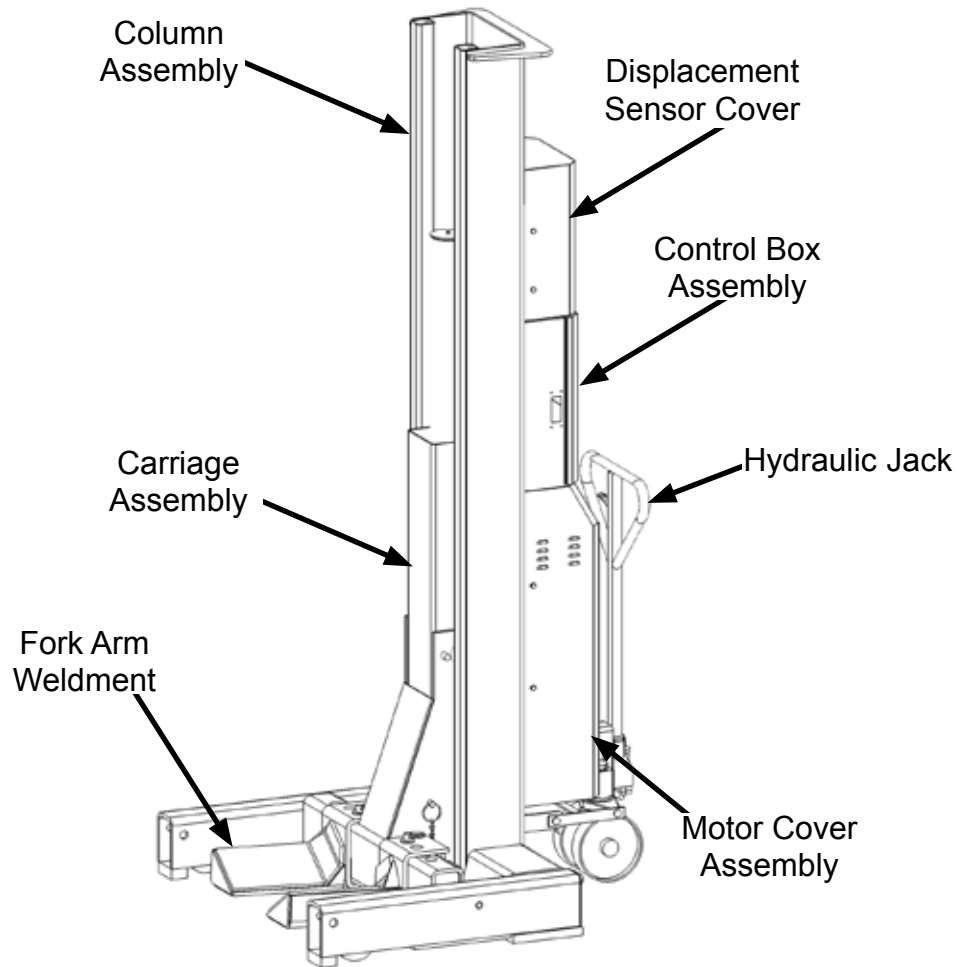

SECTION 3 (LAYOUT)

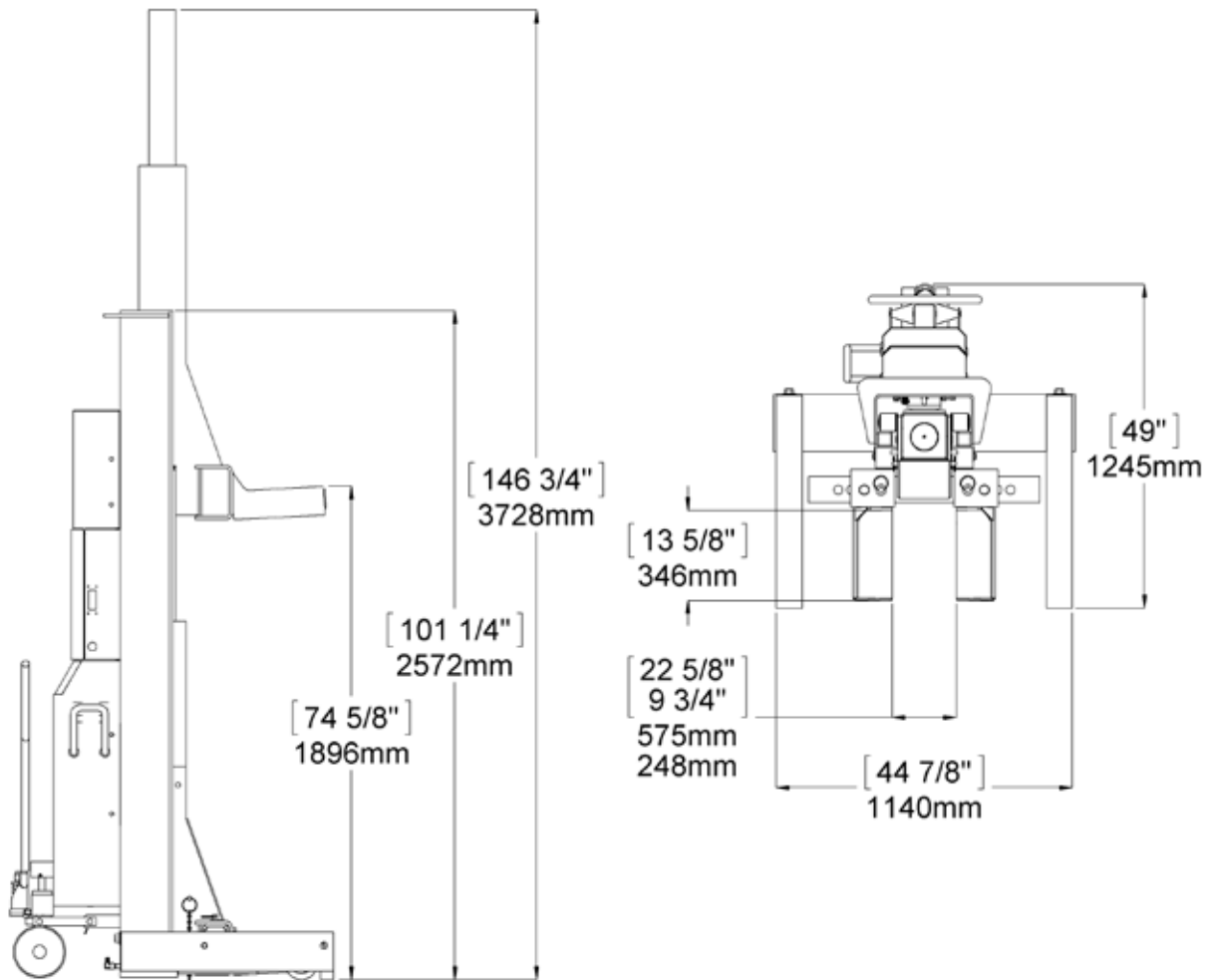

PCL-18	
Maximum Column Capacity	Each Column 18,000 Lbs. / 8,165 Kg
Maximum System Capacity / Set of Four	72,000 Lbs. / 32,659 Kg
Column Height	101 1/4" / 2,572 mm
Maximum Lifting Height	74 1/2" / 1,892 mm
Arm Fork Length	13 5/8" / 346 mm
Overall Length / Depth	49" / 1,245 mm
Width Inside Lifting Fork / Min.	9 3/4" / 248 mm
Width Inside Lifting Fork / Max.	22 5/8" / 575 mm
Overall Width	44 7/8" / 1,140 mm
Max Distance Between Columns Front/Back	360" / 9,144 mm
Max Distance Between Columns Side/Side	360" / 9,144 mm
Overhead Clearance	80" / 2,032mm. + Height of Vehicle
Lifting Speed	110 Seconds
Standard Motor *	208-230 V 50/60 Hz 3 Phase
* Special Voltages Available Upon Request	
The design, material and specifications are subject to change without notice.	

CLEARANCES

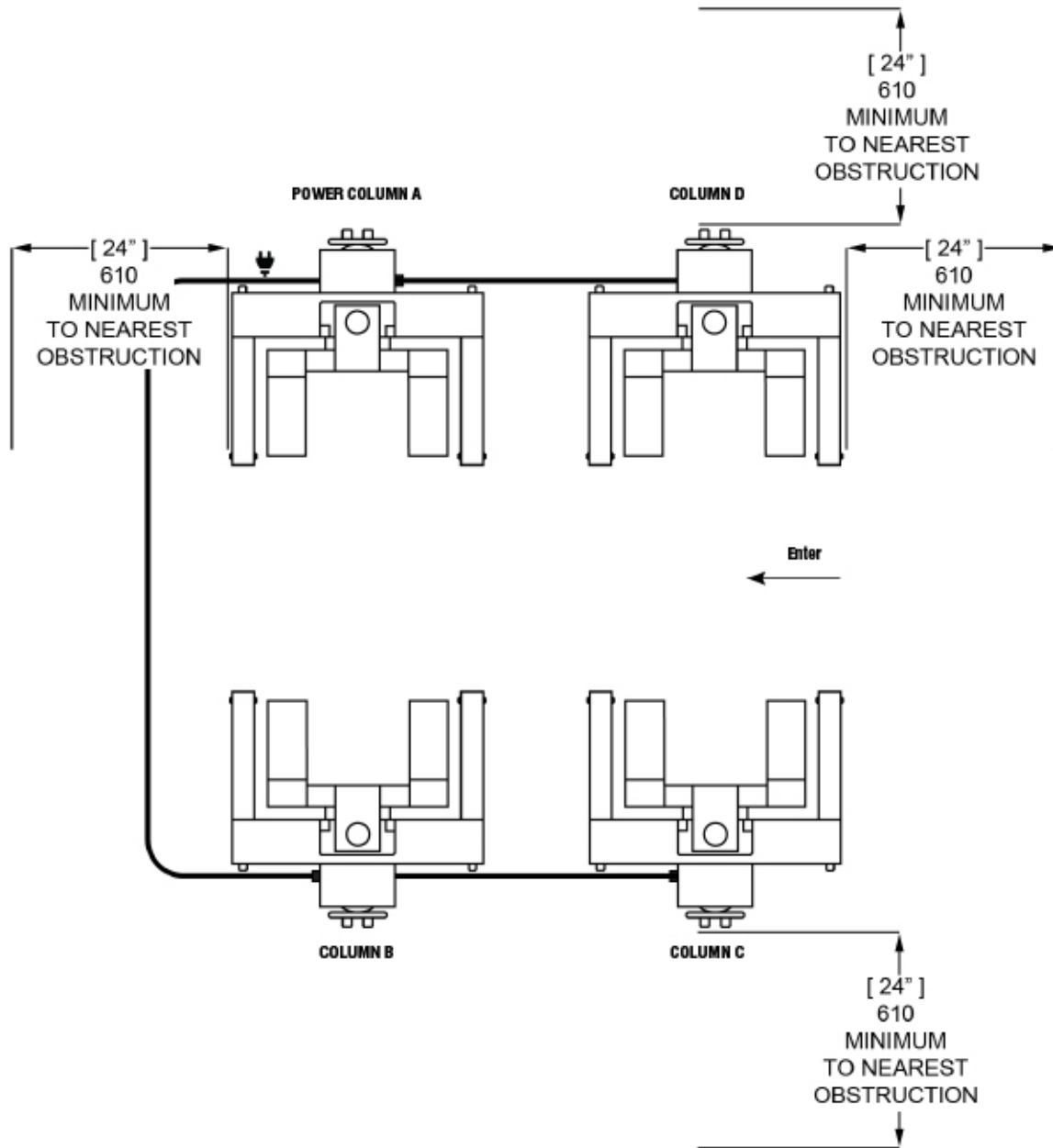

LIFT HEIGHT CLEARANCE NOTE: There must be a 148" MIN distance from ground to the nearest overhead obstruction to clear the lift at full rise.

SECTION 4 (HYDRAULIC JACKING SYSTEM)

The PCL-18 employs a Hydraulic Jacking Dolly System to move and position the Columns. The operation of the Dolly System is similar to that of a pallet Jack. (Fig. 4.1 & 4.2)

Moving the Columns

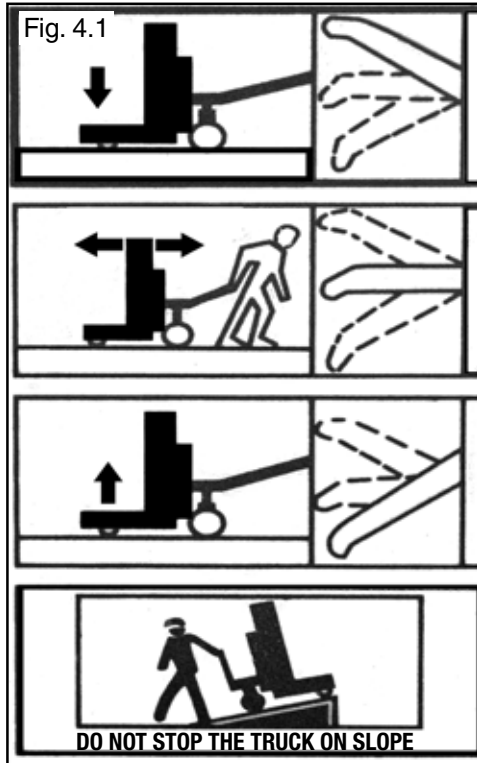

DO NOT OPERATE THE LIFT WITH THE HYDRAULIC JACK IN THE RAISED POSITION.

NEVER ATTEMPT TO MOVE A COLUMN WITH A VEHICLE LOADED ON THE ARM FORKS.

1. Position the Release Handle in the Lowest position.
2. Pump the Handle Bar down and up several times to raise the Column off the ground 1- 1.5" (25-38mm).
3. Position the Release Handle in the middle position.
4. Move the Column Assembly by pushing or pulling on the Handle Bar.
5. When the Column is in the desired location, pull up on the Release Handle and the Column will lower to the ground.

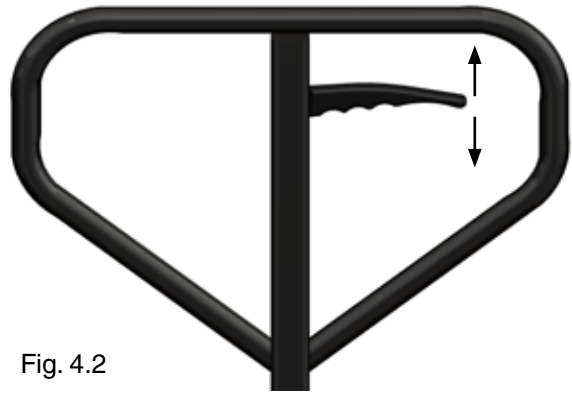

Fig. 4.2



ENSURE THE DOORS OF THE ELECTRIC CONTROL BOXES ARE CLOSED TO AVOID GETTING HANDS PINCHED OR CRUSHED BY THE HANDLE BAR.



ALL LIFTING COLUMNS MUST BE LOWERED TO THE GROUND BEFORE LIFTING OF ANY VEHICLE.

SECTION 5
(ELECTRICAL CONNECTIONS)



• ALL WIRING MUST BE PERFORMED BY A LICENSED ELECTRICIAN.



• DO NOT PERFORM ANY MAINTENANCE OR INSTALLATION OF ANY COMPONENTS WITHOUT FIRST ENSURING THAT ELECTRICAL POWER HAS BEEN DISCONNECTED AT THE SOURCE OR PANEL AND CANNOT BE RE-ENERGIZED UNTIL ALL MAINTENANCE AND/OR INSTALLATION PROCEDURES ARE COMPLETED.



• DO NOT RUN POWER UNIT WITHOUT OIL. DAMAGE TO POWER UNIT PUMP CAN OCCUR. THE POWER UNIT MUST BE KEPT DRY. DAMAGE TO POWER UNIT CAUSED BY WATER OR OTHER LIQUIDS SUCH AS DETERGENTS, ACID ETC., IS NOT COVERED UNDER WARRANTY. OPERATE LIFT ONLY BETWEEN TEMPERATURES OF 41 ° - 104° F. IMPROPER ELECTRICAL HOOK-UP CAN DAMAGE MOTOR AND WILL NOT BE COVERED UNDER WARRANTY. PROTECT EACH CIRCUIT WITH TIME DELAY FUSE OR CIRCUIT BREAKER. FOR 208-230 VOLT, THREE PHASE, USE A 50 AMP FUSE. WHEN SELECTING A PLUG MAKE SURE YOU SELECT A PLUG MADE FOR 50 AMP, 220 VAC, 3 PHASE POWER.

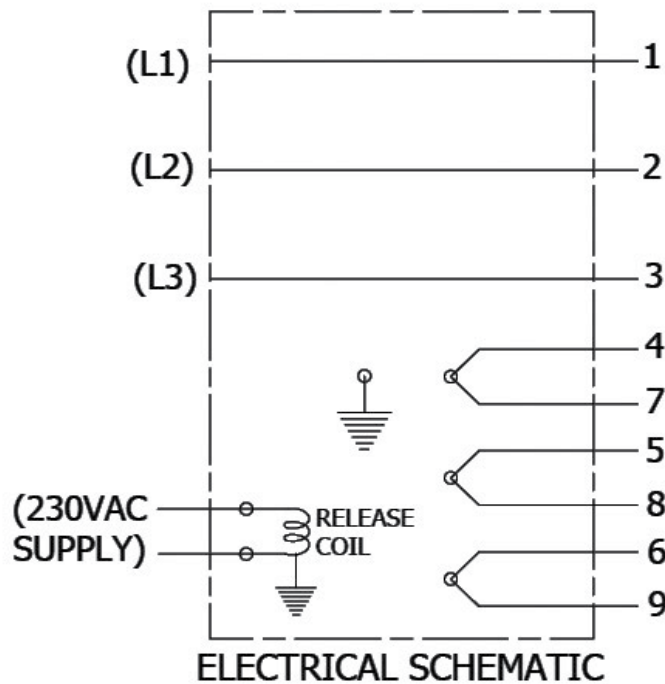

Column A

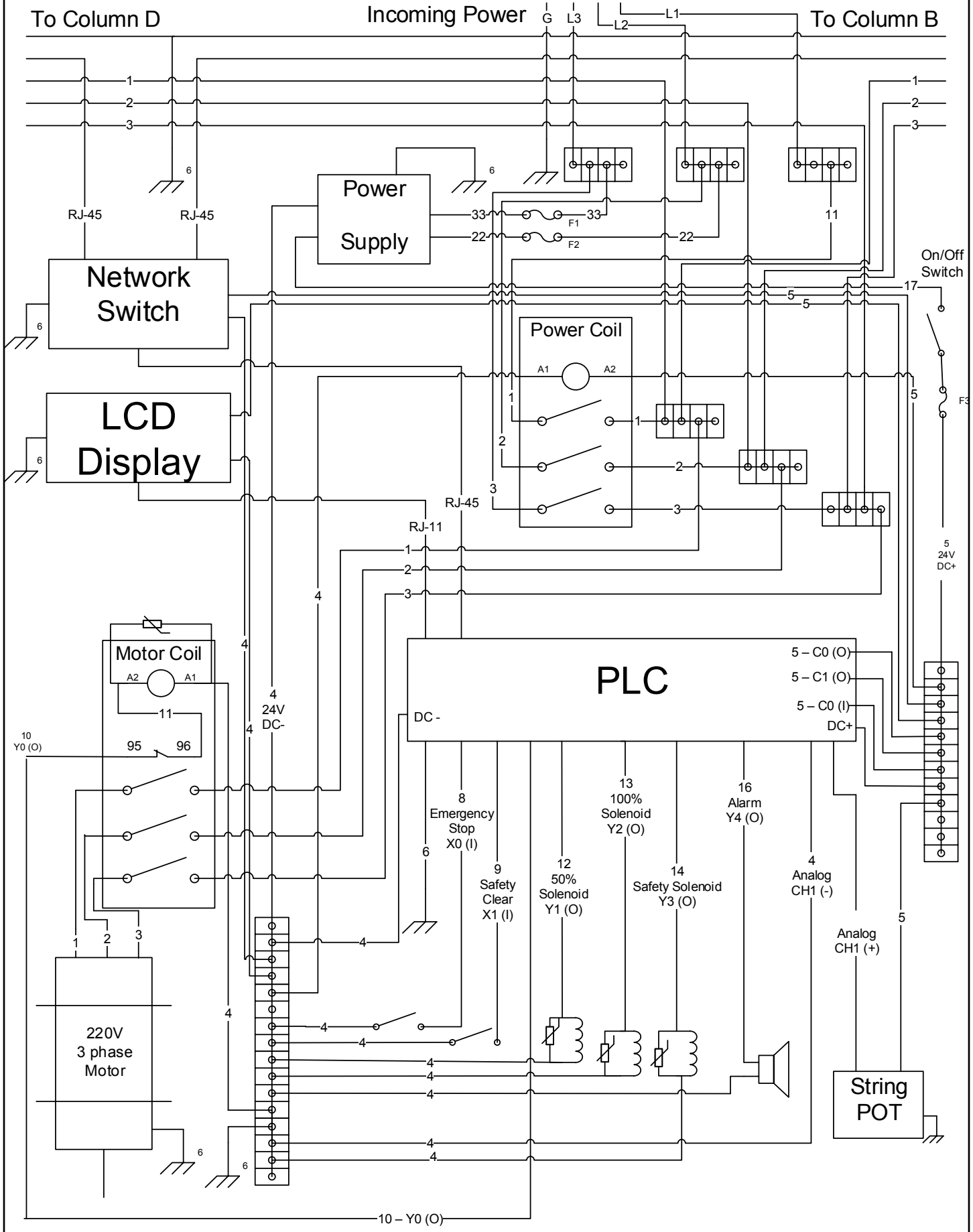

Column B

From Column A

To Column C

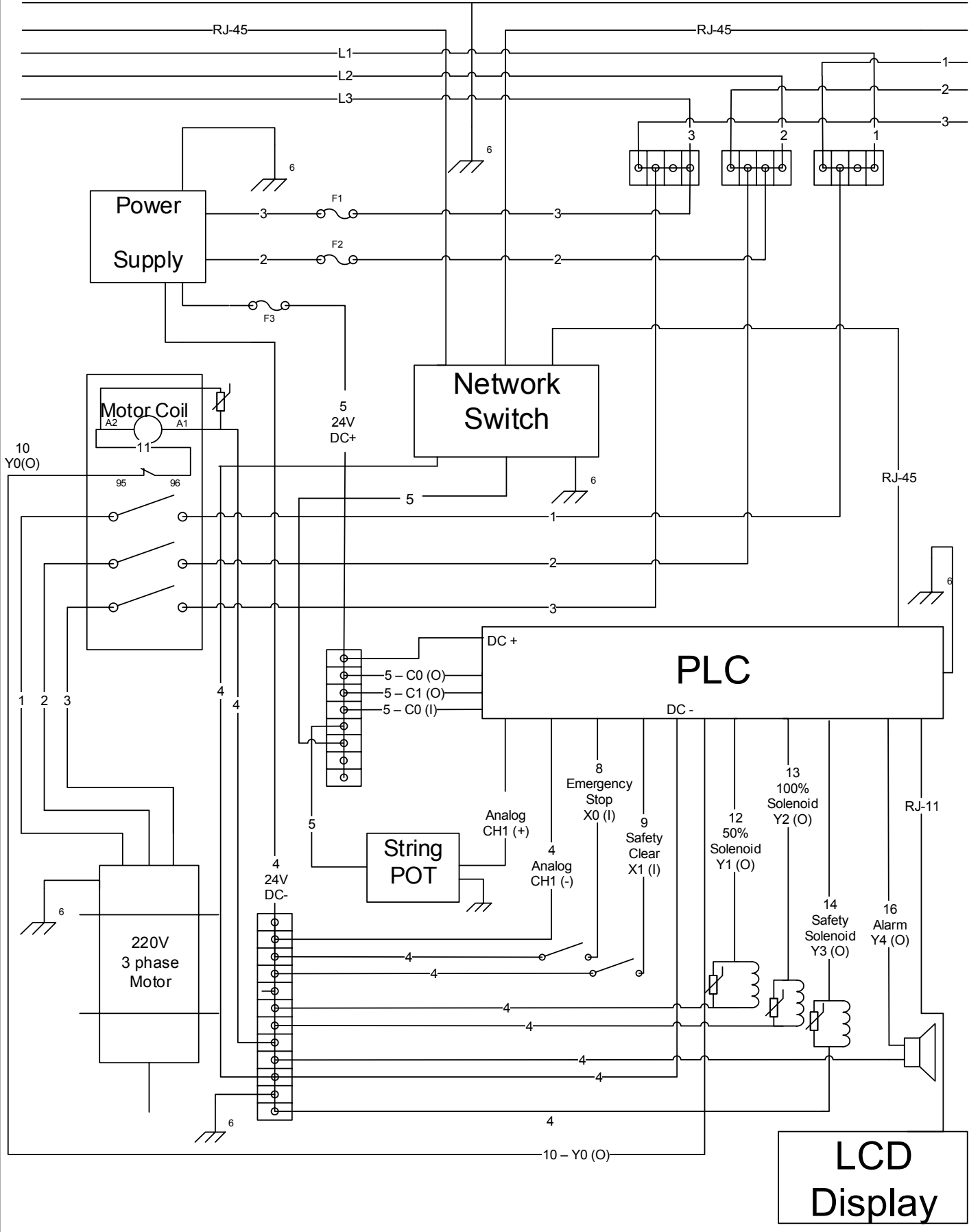

Column C & D

From Column A/B

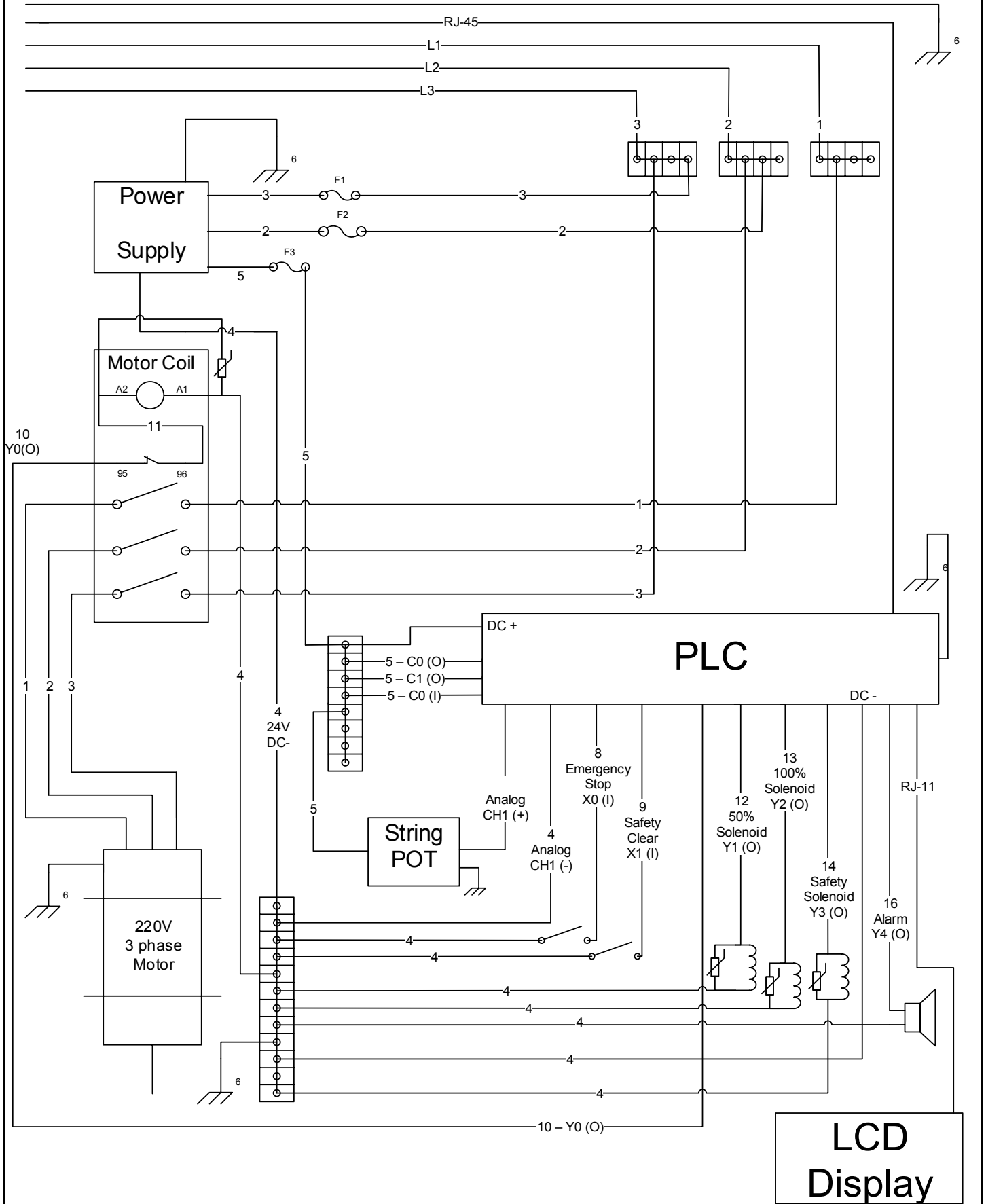

SECTION 6
(COMMUNICATION CABLE
CONNECTION AND POSITIONING
PROCEDURE)



MAIN POWER SWITCH MUST BE OFF BEFORE CONNECTING OR DISCONNECTING ANY OF THE COMMUNICATION CABLES. CONNECTION OF COMMUNICATION CABLE WHILE POWERED UP CAN RESULT IN DAMAGE TO THE ENTIRE CONTROL SYSTEM.

1. Position each column as shown below. Column A "Master Column" should be located closest to the power supply. (See Fig 6.1)
2. Route and connect the Communication Cables according to the pictures and diagrams below. Pull back on Locking Tab to lock Communication Cable to the Column connectors. (See Fig. 6.2 - 6.4)

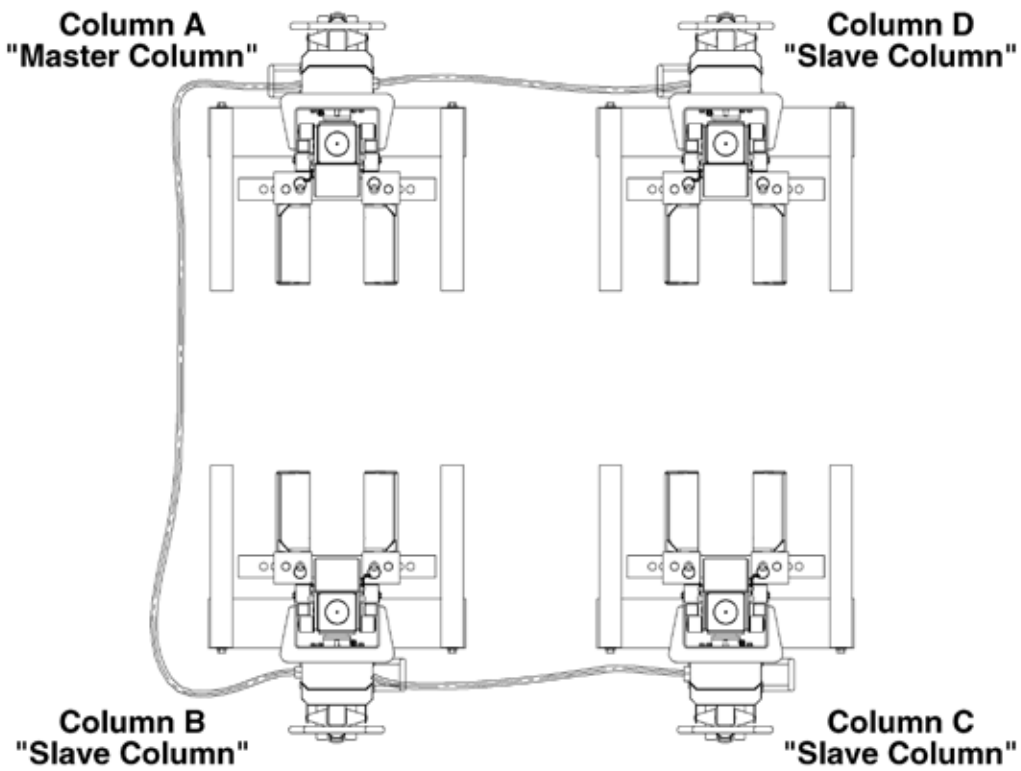

Fig. 6.1



Fig. 6.2



Fig. 6.3

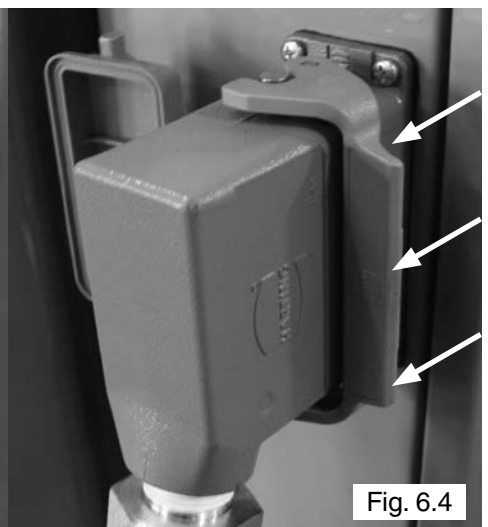

Fig. 6.4

SECTION 7 (CONTROL PANELS)

The PCL-18 includes one Master Column (Column A) and three Slave Columns (Columns B, C and D). Each Column has a control panel that can operate the Column the panel is attached to in Single Mode, the Column and the one directly across from it in Pair Mode or all 4 Columns at once in Team Mode. See Section 8 for information on Modes. The features of the Column A control panel are as follows (See Fig 7.1)

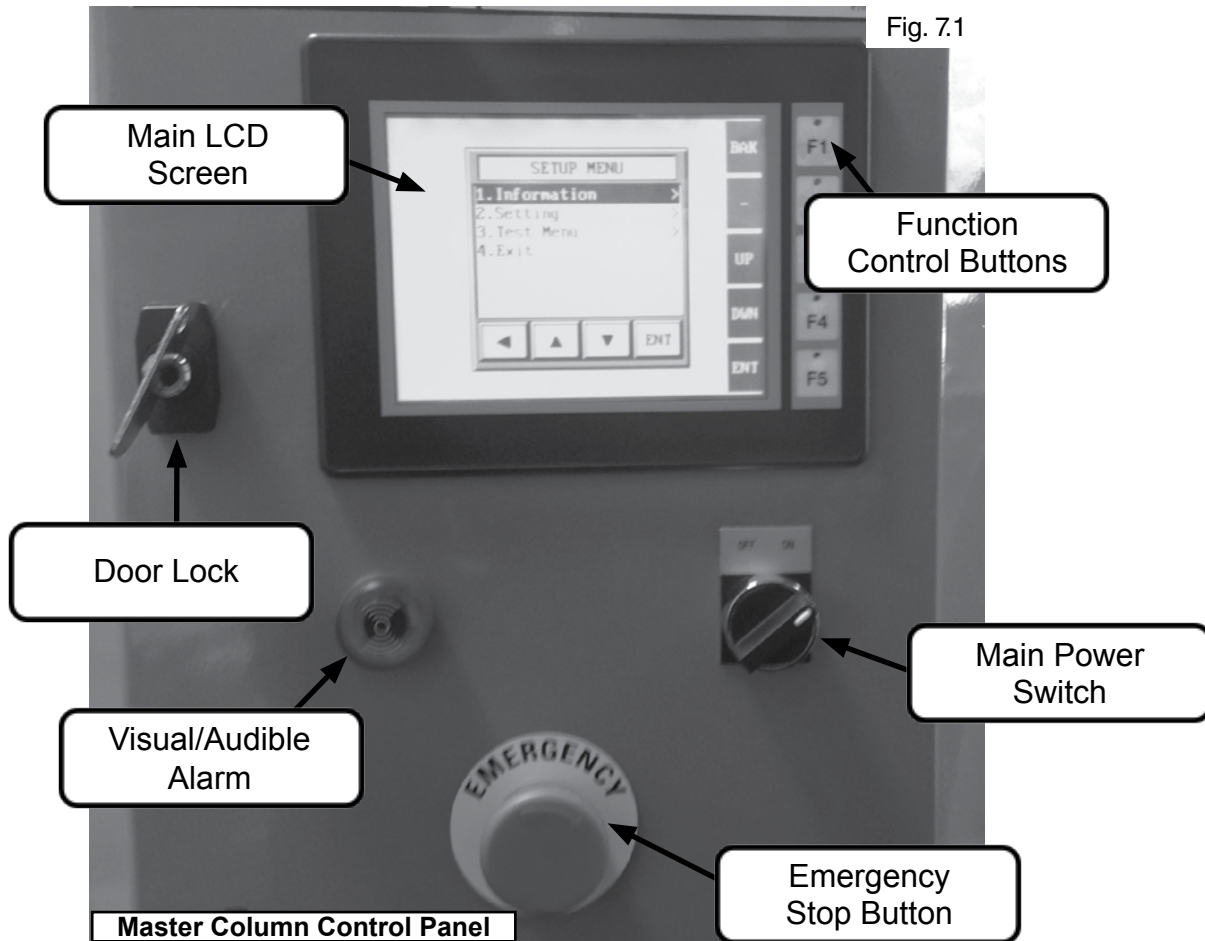

Fig. 7.1

Main Power Switch

The Main Power Switch controls power to all of the Columns. When this switch is in the “OFF” position, the lift system is powered off and not operable. When this switch is in the “ON” position, the lift system is powered on and prepared for operation.

Visual/Audible Alarm

When the Main Power switch is switched to the “ON” position, this light will illuminate and the alarm will sound. The alarm will sound and flash whenever the lift is in motion or a Fault is detected in the system.

Emergency Stop Button

Each Column has an Emergency Stop Button. Press this button on any of the Columns when you need to stop operation immediately.

To Reset, twist button clockwise. The button will pop back out.

Main LCD Screen

The Main LCD Screen displays information about the lift, such as current height of the Carriages for each Column, settings as well as any faults detected by the system. It features touch-screen capability. This means that the functions of the PCL-18 can be accessed and selected by gently touching the screen. All 4 Columns, the pair of adjacent-facing Columns, or Column A alone can be operated from the Column A Control Panel.

Function Control Buttons

These buttons to the side of the Main Display operate the functions displayed on the screen identified by the labels immediately adjacent to them.

Door Lock

The Door Lock prevents unauthorized access to the circuitry of the PCL system. Be sure the door is securely closed and locked while the lift is in operation or the Columns are being moved. Be sure if the keys are removed that they are kept in a safe place.

The Slave Column Control Panels (Columns B, C and D) have many of the same features as that of the Column A Control Panel with the following exceptions:

- There is no Power Switch
- The Display Screen is not touch-screen capable
- Information about the other Columns is not displayed on the screen
- The height limit and units of measurement can not be changed

The features of the Column B, C, and D control panels are as follows:
(See Fig 7.2)

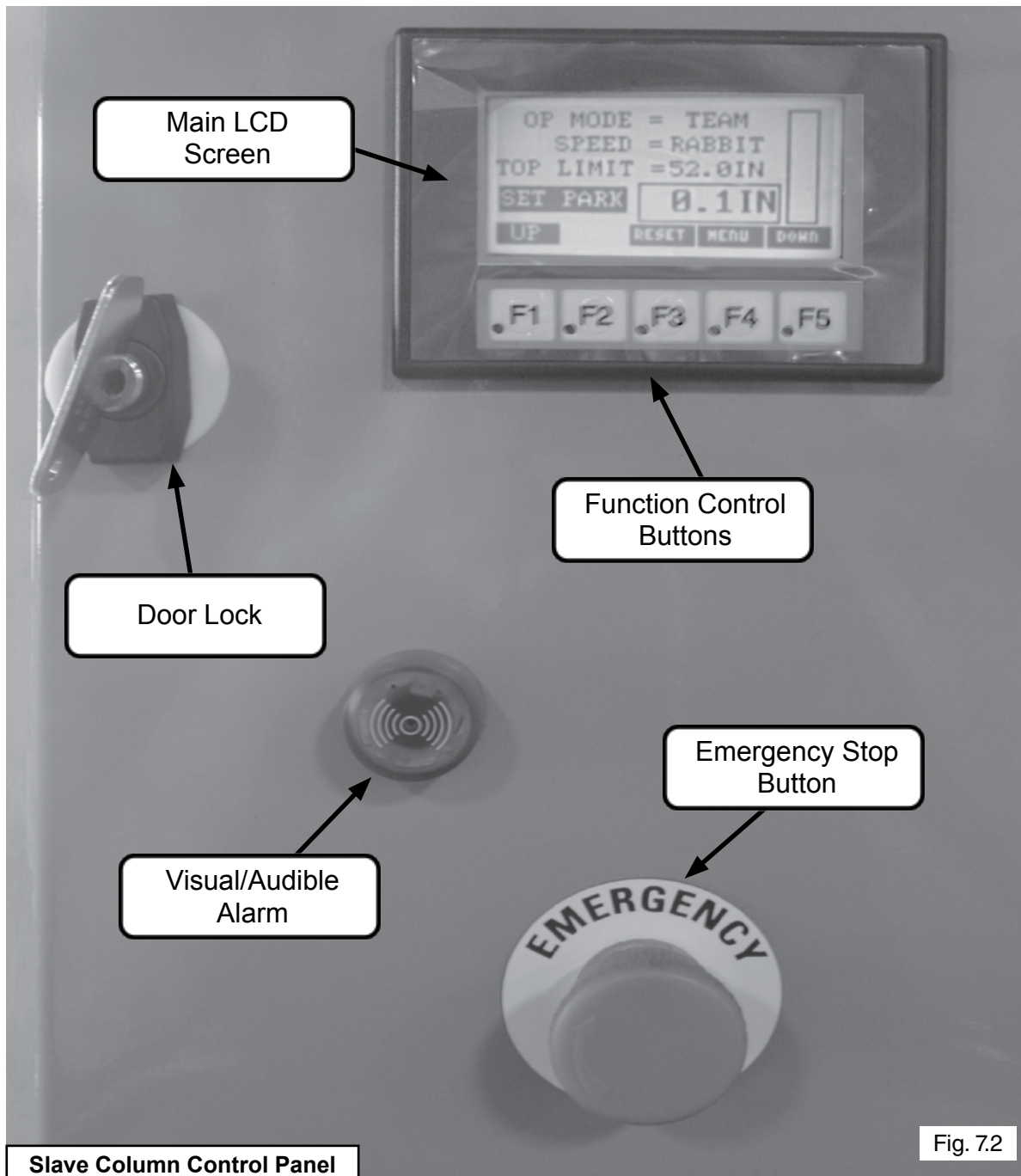

SECTION 8 (INITIAL START-UP AND PLC SYSTEM OVERVIEW)



ENSURE ALL OF THE COLUMNS ARE IN THE LOWERED POSITION AND NOT RESTING ON A RAISED HYDRAULIC JACKING DOLLY.

1. Make sure the power unit reservoirs are full with four (4) gallons of 10-WT hydraulic oil or Dexron-III automatic transmission fluid each.
2. Apply light axle grease to the inside of the posts where the slide blocks glide.
3. Once electrical power is connected to Column A and the communication cables routed to the other Columns, turn the Main Power Switch to the “ON” position.
4. After the start-up screen, the home screen should be displayed (See Fig 8.1)

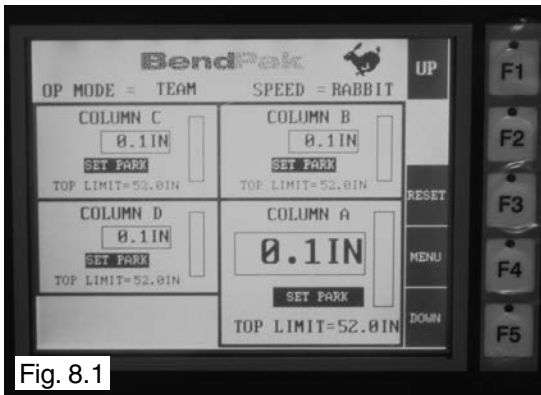

Fig. 8.1

If any of the Column heights are any value over than 0.1 IN or 0.2 IN press the “DOWN” or F5 button. If the heights still do not read correctly see Maintenance section for calibration instructions.

5. To change the settings press the “MENU” or F4 button. (See Fig 8.2)

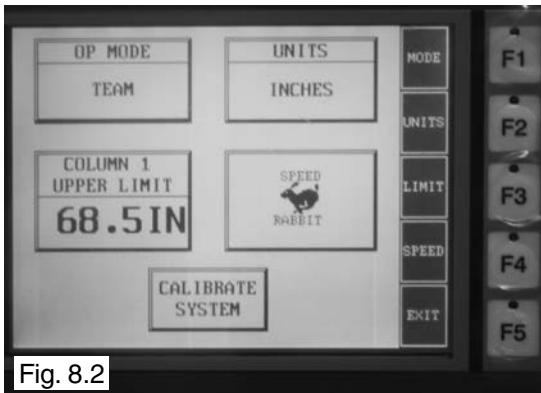

Fig. 8.2

6. Pressing **OP MODE** or F1 allows the operator to control the movement of the entire system in Team mode (See Fig 8.2), Columns A and B in Pair mode (See Fig 8.3) or Column A by itself in Single Mode (See Fig 8.4)

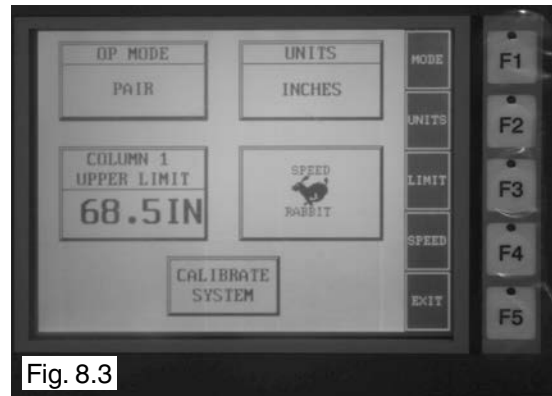

Fig. 8.3

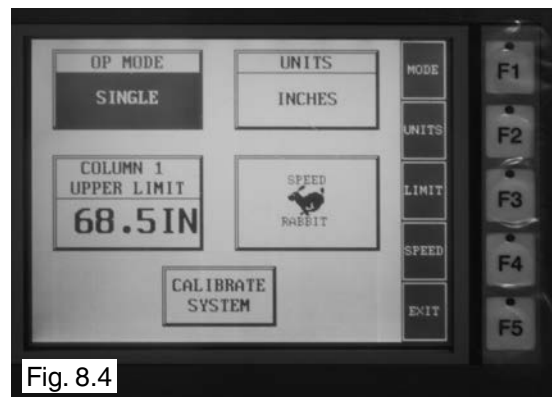

Fig. 8.4

7. Pressing **UNITS** or F2 (Column A Control Panel only) allows the operator to set the unit of measurement to either Inches (See Fig 8.5) or Millimeters. (See Fig 8.6)

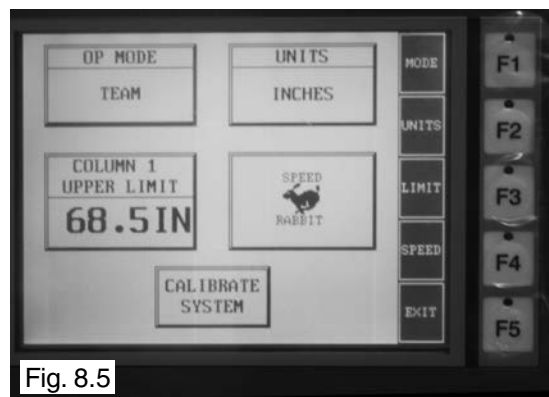

Fig. 8.5



Fig. 8.6

8. Pressing **UPPER LIMIT** or F3 (Column A Control Panel only) allows the user so set the maximum height at which the lift will stop. (See Fig 8.7)

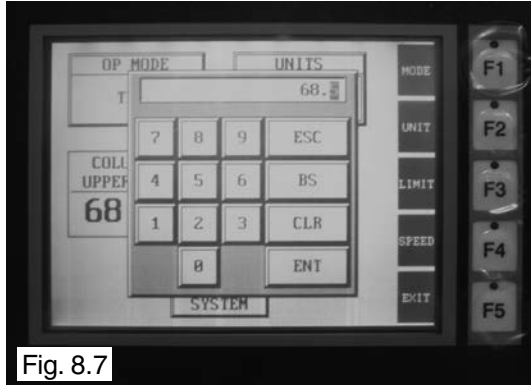

Fig. 8.7

9. Pressing **SPEED** or F4 allows the operator to change the speed at which the lift will lower when the DOWN button is pressed. Rabbit mode (See Fig 8.8) allows for a quicker descent while Turtle mode (See Fig 8.9) allows for a slower, more precise descent.

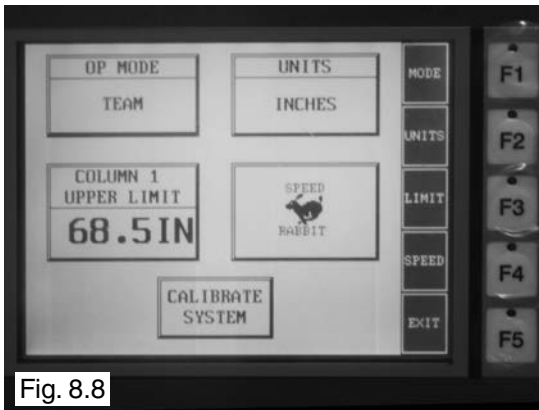

Fig. 8.8

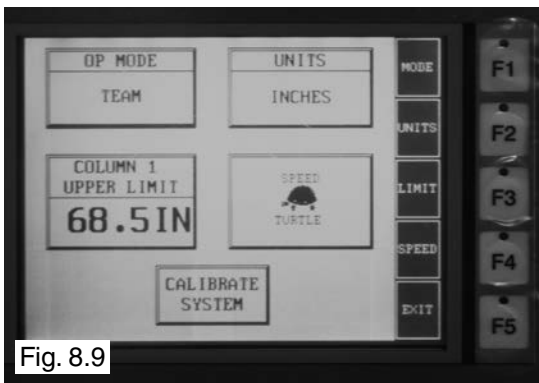

Fig. 8.9

10. Pressing **CALIBRATE SYSTEM** (Column A Control Panel only) will set the current height of the lift carriages as the 0 point or ground level. (See Fig 8.10 and 8.11)



Fig. 8.10

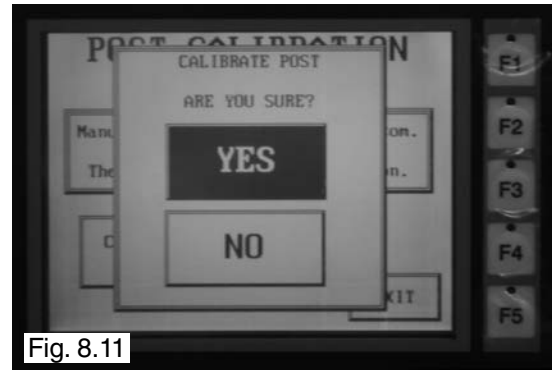

Fig. 8.11

11. Once the operator sets the desired options press the **EXIT** button or F5 to return to the home screen.

SECTION 9 (TESTING PROCEDURES)

Single Column Test

(Repeat these procedures on each Column in Single Mode.)

Lifting Test

1. After setting the Operation Mode to Single on the menu screen, raise the lift unloaded by pressing and holding the **UP** button to check if the carriage rises normally.

If the Carriage raises slowly or jerks, the Cylinder may have to be bled to release any trapped air in the hydraulic system. If not, go to Step 3.

2. Raise the carriage above about 5" \ 127mm and loosen the Cylinder Bleed Screw on the top of the Cylinder one full turn or until air or oil flows out. **DO NOT** completely remove bleed screws. Retighten after trapped air has escaped. (See Fig 9.1)

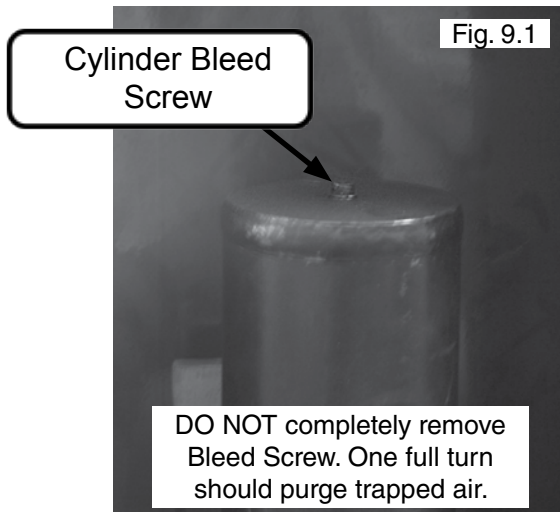

NOTE: When the PCL-18 is not loaded with a vehicle the Speed should be set to Rabbit mode or a fault condition may be detected. See page 29 for Troubleshooting and Faults.

4. Press and hold the “**DOWN**” button. The carriage will start to move up to clear the safeties and then down to the ground or until the “**DOWN**” button is released.

Emergency Button Test

5. Test the Emergency Stop Button by hitting the Emergency Stop Button while the lift is rising or lowering. The lift should immediately stop. The control panel display will turn red and an indicator will appear on the Column that had the Emergency Stop button pressed. (See Fig 9.4) To Reset, twist button clockwise. The button will pop back out.

Safety and Lowering Test

3. With the Carriage above 21”/533mm press and hold the “**PARK**” button or F2 that became available when the lift passed the indicated height. The lift will lower onto the nearest safety lock. Continue holding the “**PARK**” button until the PARKED indicator appears and the “**PARK**” button label disappears. Check that the Carriage is securely on the safety lock before continuing. (See Fig 9.2 & 9.3)

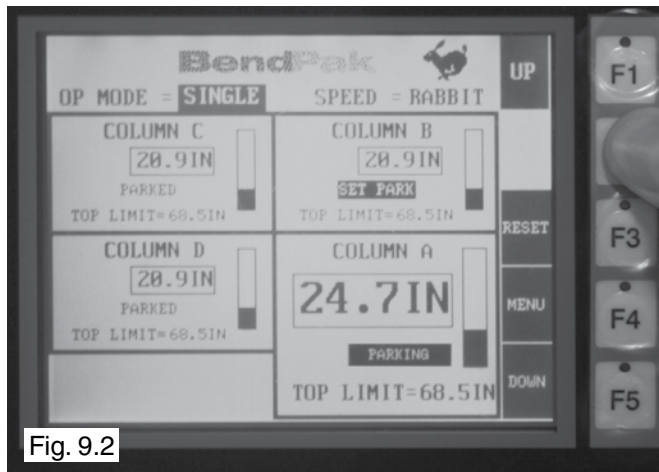
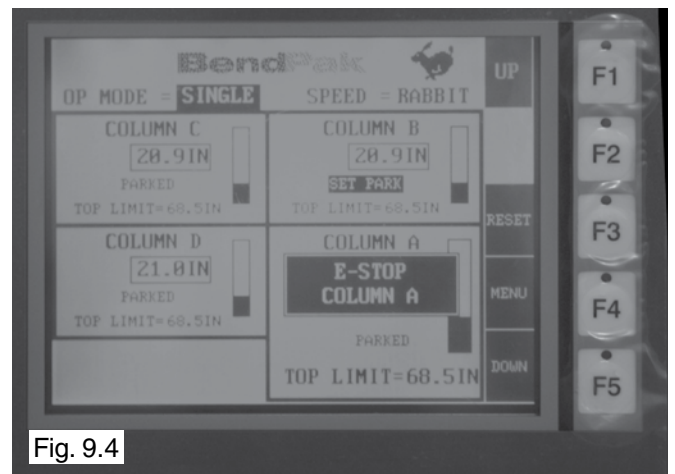

Multiple Column Test

Repeat the Lift Test, Safety Test, Lowering Test, and Emergency Stop Button Test procedure for each of the other Columns in the other Operation Modes: Pair and Team.

Remember:

- Pair mode will control the Column directly across from the Column control panel being operated.
- Team mode will control the entire system

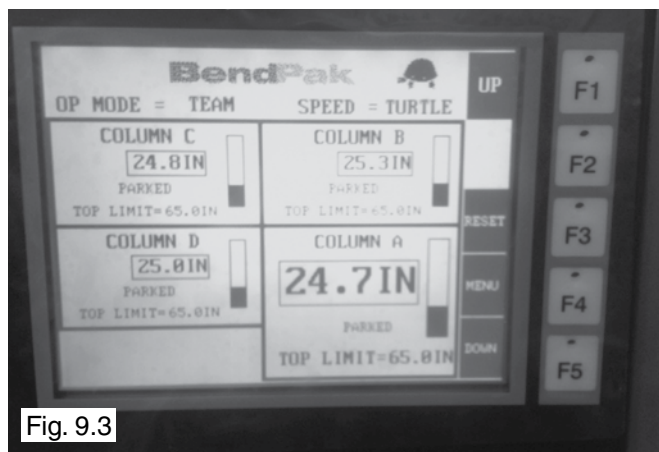

POST-INSTALLATION CHECK-OFF

- Columns properly lowered and stable
- Wheel and Arm Pins properly attached
- Electric power supply confirmed
- Safety Locks functioning properly
- Check for hydraulic leaks
- Oil level
- Lubrication of critical components
- Check for overhead obstructions
- All Screws, Bolts, and Pins securely fastened
- Surrounding area clean
- Operation, Maintenance and Safety Manuals on site.
- Perform an Operational Test with a typical vehicle

SECTION 10 (Operation Instructions)

OWNER/EMPLOYER RESPONSIBILITIES

The Owner/Employer:

- Shall ensure that lift operators are qualified and that they are trained in the safe use and operation of the lift using the manufacturer's operating instructions; ALI/SM01-1, ALI Lifting it Right safety manual; ALI/ST-90 ALI Safety Tips card; ANSI/ALI ALOIM-2000, American National Standard for Automotive Lifts-Safety Requirements for Operation, Inspection and Maintenance; ALI/WL Series, ALI Uniform Warning Label Decals/Placards; and in the case of frame engaging lifts, ALI/LP-GUIDE, Vehicle Lifting Points/Quick Reference Guide for Frame Engaging Lifts.

- Shall establish procedures to periodically inspect the lift in accordance with the lift manufacturer's instructions or ANSI/ALI ALOIM-2000, American National Standard for Automotive Lifts-Safety Requirements for Operation, Inspection and Maintenance; and The Employer shall ensure that lift inspectors are qualified and that they are adequately trained in the inspection of the lift.

- Shall establish procedures to periodically maintain the lift in accordance with the lift manufacturer's instructions or ANSI/ALI ALOIM-2000, American National Standard

for Automotive Lifts-Safety Requirements for Operation, Inspection and Maintenance; and The Employer shall ensure that lift maintenance personnel are qualified and that they are adequately trained in the maintenance of the lift.

- Shall maintain the periodic inspection and maintenance records recommended by the manufacturer or ANSI/ALI ALOIM-2000, American National Standard for Automotive Lifts-Safety Requirements for Operation, Inspection and Maintenance.

- Shall display the lift manufacturer's operating instructions; ALI/SM 93-1, ALI Lifting It Right safety manual; ALI/ST-90 ALI Safety Tips card; ANSI/ALI ALOIM-2000, American National Standard for Automotive Lifts-Safety Requirements for Operation, Inspection and Maintenance; and in the case of frame engaging lifts, ALI/LP-GUIDE, Vehicle Lifting Points/Quick Reference Guide for Frame Engaging Lifts; in a conspicuous location in the lift area convenient to the operator.

- Shall provide necessary lockout/tagout means for energy sources per ANSI Z244.1-1982 (R1993), Safety Requirements for the Lockout/Tagout of Energy Sources, before beginning any lift repairs.

- Shall not modify the lift in any manner without the prior written consent of the manufacturer.



LIFT OPERATION SAFETY

- **DAILY** inspect your lift. Never operate if it malfunctions or if it has broken or damaged parts. Use **only** qualified lift service personnel and genuine BendPak parts to make repairs.
- **THOROUGHLY** train all employees in use and care of lift, using manufacturer's instructions and "Lifting It Right" and "Safety Tips" supplied with the lift.
- **NEVER** allow unauthorized or untrained persons to position vehicle or operate lift.
- **PROHIBIT** unauthorized persons from being in shop area while lift is in use.
- **DO NOT** permit anyone on lift or inside vehicle when it is either being raised or lowered.
- **ALWAYS** keep area around lift free of tools, debris, grease and oil.
- **NEVER** overload lift. Capacity of lift is shown on nameplate affixed to the lift.
- **DO NOT** stand in front of the vehicle while it is being positioned in lift bay.
- **DO NOT** hit or run over lift arms, legs or cables. This could damage lift or vehicle. Before driving vehicle into position, move Columns to provide unobstructed access to lift area.
- **ALWAYS** load vehicle on lift carefully. Position the lift arms to contact at the vehicle's wheels. Raise lift until the wheels are 2"/50mm off ground. Check arms for secure contact with wheels. Raise lift to desired working height.



CONFIRM THAT ALL PRIMARY SAFETY LOCKS ARE ENGAGED BEFORE ENTERING WORK AREA. CYLINDER COMPONENTS USED ON THIS LIFT ARE INTENDED TO RAISE AND LOWER LIFT ONLY AND ARE NOT MEANT TO BE LOAD HOLDING DEVICES. REMAIN CLEAR OF ELEVATED LIFT UNLESS CONFIRMATION IS MADE THAT ALL PRIMARY SAFETY LOCKS ARE FULLY ENGAGED AND THE LIFT IS LOWERED ONTO THE SAFETY LOCKS, REFER TO INSTALLATION /OPERATION MANUAL FOR PROPER SAFETY

- **DO NOT** block open or override self-closing lift controls; they are designed to return to the "Off" or Neutral position when released.
- **DO NOT** remove or disable arm restraints.

- **ALWAYS** remain clear of lift when raising or lowering vehicles.
- **ALWAYS** use safety stands when removing or installing heavy components.
- **DO NOT** go under raised vehicle if safety locks are not engaged.
- **NEVER LEAVE LIFT IN ELEVATED CONDITION** unless all Safety Locks are engaged.
- **AVOID** excessive rocking of vehicle while on lift.
- **ALWAYS CLEAR AREA** if vehicle is in danger of falling.
- **ALWAYS REMOVE** tool trays, stands, etc. before lowering lift.



WHEN LOWERING THE LIFT PAY CAREFUL ATTENTION THAT ALL PERSONNEL AND OBJECTS ARE KEPT CLEAR. ALWAYS KEEP A VISUAL LINE OF SITE ON THE LIFT AT ALL TIMES. ALWAYS MAKE SURE THAT ALL LOCKS ARE DISENGAGED. IF ONE OF THE LOCKS INADVERTENTLY LOCKS UPON DESCENT THE VEHICLE MAY DISMOUNT CAUSING PERSONAL INJURY OR DEATH.

- **ALWAYS POSITION** the Columns to provide an unobstructed exit before removing vehicle from lift area.
- **DO NOT** raise or lower the lift with persons or equipment under the vehicle at any time.
- All vehicle tires need to be inspected and properly inflated according to vehicle manufactures specifications.
- **DO NOT** lift any vehicle with any of the tires under inflated, flat, or with any damage or wear that could compromise the load bearing capability of the tire.
- Ensure that all steerable wheels are pointed straight and are parallel to the vehicle body.
- Ensure there is a minimum of 6"/152mm clearance above the top of the vehicle.
- **NEVER** attempt to override any fault condition.
- **DO NOT** operate the lift with any fault condition present.
- **ALWAYS** lower all columns onto the ground after positioning or for storage.
- **DO NOT** apply a horizontal force or load to any raised

vehicle that exceeds more than 20% of the vehicles gross weight during any repair procedures.

- Protect the communication cables from damage from sharp objects.
- **DO NOT** drive over communication cables.
- Read and comply with all safety guidelines and recommendations.

TO RAISE LIFT

1. Perform the Lift Testing Procedure as outlined in Section 9 before lifting any vehicle.



TO AVOID PERSONAL INJURY AND/OR PROPERTY DAMAGE, PERMIT ONLY TRAINED PERSONNEL TO OPERATE LIFT. AFTER REVIEWING THESE INSTRUCTIONS, PRACTICE USING LIFT CONTROLS BY RUNNING THE LIFT THROUGH A FEW UNLOADED CYCLES BEFORE LOADING VEHICLE ON LIFT. ALWAYS LIFT THE VEHICLE USING ALL FOUR COLUMNS. NEVER RAISE JUST ONE END, ONE CORNER, OR ONE SIDE OF VEHICLE.



MAIN POWER SWITCH MUST BE OFF BEFORE CONNECTING OR DISCONNECTING ANY OF THE CABLES. CONNECTION OF CABLES WHILE POWERED UP CAN RESULT IN DAMAGE TO THE ENTIRE CONTROL SYSTEM.



DO NOT LIFT ANY VEHICLE WITH ANY OF THE TIRES UNDER INFLATED, UN-INFLATED, OR WITH ANY DAMAGE OR WEAR THAT COULD COMPROMISE THE LOAD BEARING CAPABILITY OF THE TIRE.

2. Position the Vehicle on solid concrete surface.
3. Confirm that the vehicles tires are all properly inflated.

Confirm that the gross vehicle's weight does not exceed that of the total capacity of the lifting system.

4. Adjust the fork arms by removing the Arm Locking Pins and sliding the fork arms so that they are spaced wider than the tire diameter of the vehicle. (See Fig 10.1)

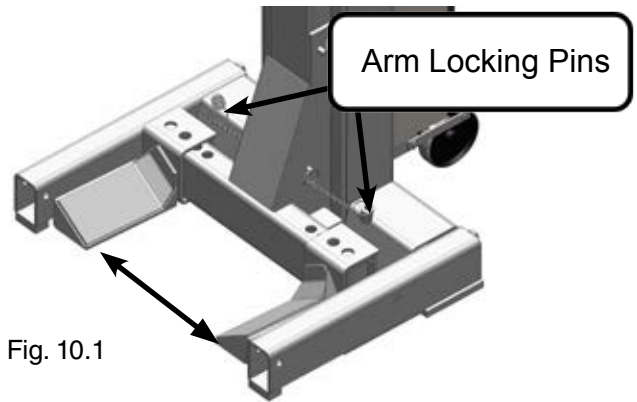

Fig. 10.1

5. Using the Hydraulic Jacking System, position each Column so that the forks of the lift are positioned properly around each of the vehicles wheels. The wheels should be centered between the forks. (See Fig 10.2)



Fig. 10.2

6. Lower the Column and adjust the fork arms by pushing the arms until they touch or are as close to the tire as possible. The lift should be parallel to the vehicle body without touching the body or other components of the vehicle. (See Fig 10.3)

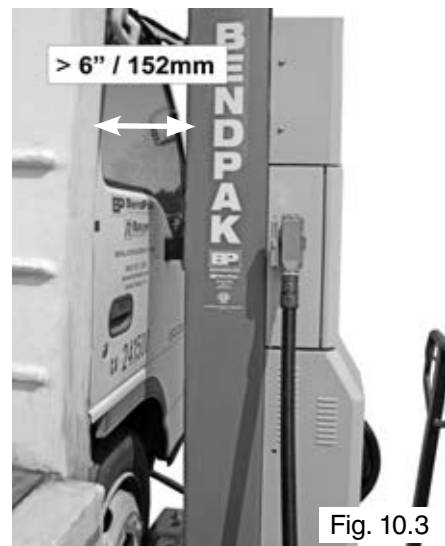

Fig. 10.3

7. When all the Columns are properly positioned and the clearances around and above the vehicle are confirmed clear of obstructions, the Columns can be connected.

8. Keep the Communication Cables clear of sharp objects and foot paths. DO NOT drive over communication cables.

9. Make sure the main Power Switch is in the “OFF” Position.

11. Connect the Master Column to the Power source. Connect Columns to each other. Refer to Section 6 for communication cable routing.

12. After connecting the Communication Cables, turn the Main Power Switch to “ON”. There should be no fault indications.

Raising a Vehicle

13. Press and hold the “UP” button at Column A Control Panel. Raise the vehicle to a height of 2” (50mm).

14. Inspect each Column:

- ◆ Ensure all lifting contact points are in good condition.
- ◆ Make sure the tires are properly inflated and are not deforming under the load.
- ◆ Confirm the Columns are lowered all the way to the ground.
- ◆ Arm Locking Pins are properly positioned.
- ◆ Confirm over head Clearances.

15. Raise the Vehicle to the desired working height. The minimum safety height is 21”/533mm. Once past this height, hold **PARK** button or F2 that became available when the lift passed the indicated height. The lift will lower onto the nearest safety lock. Continue holding the **PARK** button until the **PARKED** indicator appears and the **PARK** sign disappears. Check that the Carriage is securely on the safety lock before continuing.



CONFIRM THAT ALL PRIMARY SAFETY LOCKS ARE ENGAGED BEFORE ENTERING WORK AREA. CYLINDER COMPONENTS USED ON THIS LIFT ARE INTENDED TO RAISE AND LOWER LIFT ONLY AND ARE NOT MEANT TO BE LOAD HOLDING DEVICES. REMAIN CLEAR OF ELEVATED LIFT UNLESS CONFIRMATION IS MADE THAT ALL PRIMARY SAFETY LOCKS ARE FULLY ENGAGED AND THE LIFT IS LOWERED ONTO THE SAFETY LOCKS.

NOTE: Columns may start, stop or slow in relation to the other Columns without triggering a fault. This is normal operation as the Control Unit automatically levels the vehicle by controlling the rate of rise or descent individually.

While Using Lift

- Avoid excessive rocking of vehicle while on lift.



WHEN LOWERING THE LIFT PAY CAREFUL ATTENTION THAT ALL PERSONNEL AND OBJECTS ARE KEPT CLEAR. ALWAYS KEEP A VISUAL LINE OF SITE ON THE LIFT AT ALL TIMES. ALWAYS MAKE SURE THAT ALL LOCKS ARE DISENGAGED. IF ONE OF THE LOCKS INADVERTENTLY LOCKS ON DESCENT THE LIFT AND/OR VEHICLE MAY DISRUPT CAUSING PERSONAL INJURY OR DEATH.

- Always use safety stands as needed or when removing or installing heavy components.

Lowering a Vehicle

16. Before lowering vehicle, be sure all personnel are clear of the lift and surrounding area. Pay careful attention to overhead clearances. Ensure all tools and equipment have been cleared from under the lift.

17. Press and hold the “DOWN” button until vehicle reaches the ground.

18. Inspect each Column to confirm each Column is lowered all the way to the ground.

19. Disconnect each cable assembly and wrap it onto the Cable hooks on the side of the Columns.

20. Pump the Handle Bar Down and Up several times to raise the Column Assembly off the ground 1- 1.5” (25-38mm)

21. Pull the Column Assemblies away from the Vehicles and store in a safe place.

22. After clearing all the Column Assemblies and Cables from the vehicles, move the lift away from it and then drive the vehicle away.

MAINTENANCE INSTRUCTIONS



IF YOU ARE NOT COMPLETELY FAMILIAR WITH AUTOMOTIVE LIFT MAINTENANCE PROCEDURES; STOP AND CONTACT THE MANUFACTURER FOR INSTRUCTIONS. TO AVOID PERSONAL INJURY, PERMIT ONLY QUALIFIED PERSONNEL TO PERFORM MAINTENANCE ON THIS EQUIPMENT.

- **Always:** replace ALL FAULTY PARTS before lift is put back into operation.
- **Always:** keep bolts tight. Check periodically.
- **Always:** keep lift components clean.
- **Always:** if oil leakage is observed, call local service representative.
- **Always:** if electrical problems develop, call local service representative.
- **Daily:** Make a visual inspection of ALL MOVING PARTS and check for excessive signs of wear.
- **Daily:** Check safety locks to ensure they are in good operating condition.
- **Weekly:** Lubricate all moving components.
- **Semi-annually:** check fluid level of lift power unit and refill if required per lift installation instructions.
- **Replace** all caution, warning or safety related decals on the lift if unable to read or missing. Reorder labels from Bendpak.
- Refer to ANSI/ALI ALOIM booklet for periodic inspection checklist and maintenance log sheet.

Cleaning the Display Screen

- The display screen should be cleaned periodically by wiping it with a lint free damp cloth using a mild soap solution. Dry the surface when finished with a lint free cloth. Do not clean with ammonia based products. The ABS material the bezel is made from is reactive with ammonia.
- The longevity of the display can be increased by the

use of a non-glare screen protector.

- To prevent damage to the display screen, avoid touching the screen with sharp objects, striking the screen with a hard object, the use of abrasives near the screen, or using excessive force when pressing the touch screen. In the event that the touch screen membrane becomes damaged or scratched, the bezel, which includes the clear membrane window, can be replaced.

Lubrication

- Raise the lift and Park on the top most safety position.
- Through the top and bottom of each Column, apply a light coat of grease on the frontal face and internal face of the Column Rails. See Figures Below.

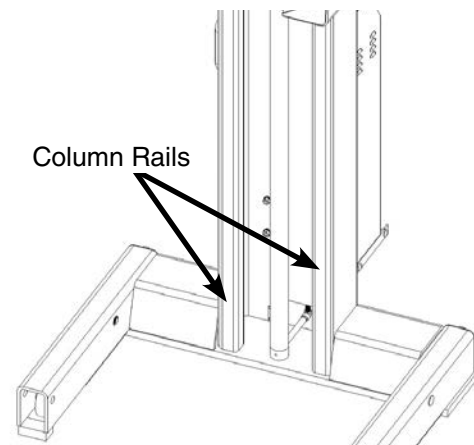
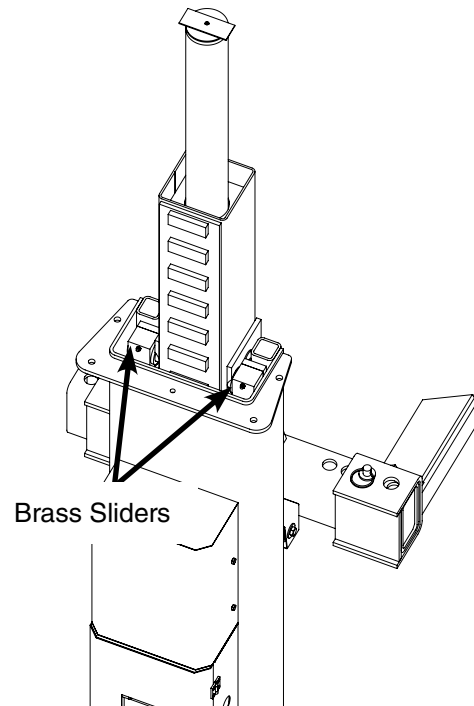

PCL-18 PRODUCT DECAL POSITIONING

A

WARNING

- ✓ **READ AND UNDERSTAND** all installation and operation instructions as outlined in all manuals thoroughly before installing, operating or servicing this lift.
- ✓ **THOROUGHLY TRAIN ALL EMPLOYEES** in use and care of the lift, using manufacturer's instructions and "Lifting Rights and Safety Instructions".
- ✓ **NEVER** allow untrained or untrained persons to position vehicle/lift or operate lift.
- ✓ **DO NOT USE LIFT** in a manner other than intended. Included but not limited to examples of unapproved uses of the lift would be lifting vehicle by only one side, lifting different sides with a column post (diagonal lifting), and lifting non-approved items or vehicles.
- ✓ **ALWAYS** become familiar with and understand all lift controls before loading a vehicle onto lift.
- ✓ **NEVER** use on asphalt or soft ground surfaces. Operate lift only on concrete with a minimum strength of 3000 psi and a minimum thickness of 4" (2").
- ✓ **MAXIMUM ALLOWED FLOOR SLOPE** is 1/8" per foot side to side of vehicle and 1/4" per foot front to rear of vehicle.
- ✓ **NEVER** use on a suspended floor structure without specific approval from structural engineer.
- ✓ **OBSERVE AND FOLLOW** all safety and warning labels found on the lift and illustrated in the installation and operators manuals.
- ✓ Electrical components on this lift have internal arcing or sparking parts. To minimize the risk of explosion, **DO NOT** repair or tamper with capacitors or operate lift in the vicinity of open containers of flammable liquids.
- ✓ **ALWAYS** ensure tires are properly inflated before lifting. **NEVER** exceed tire load rating when raising vehicle.
- ✓ **NEVER** use/lower only one side of a vehicle or vehicle may come in contact with lift columns as vehicle tips.
- ✓ **ALWAYS** sit simultaneously on same side and **NEVER** stagger between sides.
- ✓ **NEVER** drive over or crush electrical cables.
- ✓ **NEVER** use if electrical cords are resting in/on standing water, snow or damp floor surfaces.
- ✓ The equipment has an **OPERATING AMBIENT TEMPERATURE RANGE** of 41°-104°F (5°-40°C).

COLUMN CONFIGURATIONS

2-COLUMN CONFIGURATION (Note: Special factory configuration only)

4-COLUMN CONFIGURATION

6-COLUMN CONFIGURATION

8-COLUMN CONFIGURATION

NOTE: The electrical communication cables do not have to make a complete loop. It is not necessary to plug the last lift back into the first lift. SEE DIAGRAM.

PCL-18_Warnings.pdf:
 Trim: 6"W x 19"H
 Material: 2 Mil. White Adhesive Vinyl
 Ink: U.V. protected CMYK 4/C Process
 Finish: Polished
 Print Process: Offset Lithography - 200 line-screen or 300 p.p.i. for digital
 Lamination: Clear-gloss over-laminate for abrasion, chemical, and ultra violet protection

B

ATTENTION

MAXIMUM LIFTING CAPACITY

18000 Lbs.

8165 Kg.

PN 090675

NRTL_Listing_Cap_Label_18K.pdf:
 Trim: 4.5"W x 3.25"H
 Material: 2 Mil. White Adhesive Vinyl
 Ink: U.V. protected CMYK 4/C Process
 Finish: Polished
 Print Process: Offset Lithography - 200 line-screen or 300 p.p.i. for digital
 Lamination: Clear-gloss over-laminate for abrasion, chemical, and ultra violet protection

C

WARNING Clear area if vehicle is in danger of falling.

WARNING Remove clear of lift when raising or lowering vehicle.

NOTICE Read operating and safety instructions and equipment manual before operation.

NOTICE Proper maintenance and inspection are mandatory for safe operation.

WARNING Lateral lift on firm, level surface, preferably concrete.

WARNING Do not interlock lifts are moving together evenly.

NOTICE Do not operate a damaged lift.

CAUTION The maximum and minimum clearances must be maintained at all times. The amount of ground clearance must be maintained at all times. The maximum number of lifts must not exceed the number of lifts permitted on the lift. See lift manual for details.

CAUTION Maintenance and safety labels may be removed or damaged. If any labels are missing, contact your distributor for replacement. See lift manual for details.

WARNING All lifting forks must properly engage vehicle tires at all times.

WARNING Do not drive over or crush electrical cables.

CAUTION Lift to be used only on lift area.

CAUTION Multiple lifts permitted on lift area.

WARNING Keep feet clear of lift while lowering.

CAUTION When moving lift, be careful to avoid tipping.

CAUTION Check for overhead obstructions before raising vehicle.

ALI-Warning-Labels-Mobile-Column-Lifts

A

B



PCL-18 PRODUCT DECAL POSITIONING

D

⚠ WARNING	QUICK-START OPERATION INSTRUCTIONS
<ul style="list-style-type: none"> Be sure to observe and follow all safety and warning instructions found on the lift, illustrated on the labels and in the installation and operators manual(s). Before attempting to lift any vehicle, be sure that vehicle individual axle weight does not exceed two lift columns combined capacity and adequate overhead clearance is provided to raise vehicle to desired height. Make sure lift forks are in secure contact with vehicle tires and parking brake is released on vehicle. Adjustable forks must be equally spaced off centerline of lift carriage and adjusted properly to the tire/wheel size. Ensure tires are properly inflated before lifting. DO NOT exceed tire load rating when raising vehicle. NEVER go under raised vehicle unless all tires are making secure contact with the forks. Lower lift and repeat vehicle and/or lift spotting and loading procedure if necessary. <p>Failure to read, understand and follow these instructions may cause death or serious injury. Read and understand these instructions before using lift.</p>	<p>TO RAISE LIFT:</p> <ol style="list-style-type: none"> After ensuring that the system communication check is complete and the display panel is colored GREEN, press the UP button until all vehicle tires clear the floor. (NOTE: If any single column has an operation fault, the entire set of columns will fail to register and the display panel(s) will be colored RED). Stop and check for secure fork contact with tires at all columns. Continue to raise vehicle to the desired height. (NOTE: If top limit has been set, the lift will automatically stop rising at the desired limit setting). NOTE: While operating the lift, you will observe individual columns slowing down and/or speeding up at various intervals of travel. This is a normal operating characteristic of the system. Press the PARK button to lower lift onto the locking latches. While using lift, avoid excessive rocking of vehicle. <p>TO LOWER LIFT:</p> <ol style="list-style-type: none"> Before lowering lift, be sure to remove tool carts, safety stands, etc. from the area and check that all personnel and bystanders remain clear. After ensuring that the system communication check is complete and the display panel is colored GREEN, press the DOWN button to lower lift. NOTE: The RABBIT (🐰) or TURTLE (🐢) settings can be used to control the lowering speed if desired. Observe that all columns are lowering and vehicle remains level. Remain clear of forks and vehicle when lowering. Observe pinch point WARNING decals. Reset the parking brake. Move all lift units away from the vehicle to provide an unobstructed exit before removing the vehicle. NEVER drive vehicle over communication cables. <p style="text-align: right; font-size: small;">PW 000020</p>

PCL-18_Instructions.pdf:
Trim: 9.5"W x 6.25"H

Material: 2 Mil. White Adhesive Vinyl
Ink: U.V. protected CMYK 4/C Process
Finish: Polished

Print Process: Offset Lithography - 200 line-screen or 300 p.p.i. for digital

Lamination: Clear-gloss over-laminate for abrasion, chemical, and ultra violet protection

C

D



⚠ WARNING ⚠

- ✓ **READ AND UNDERSTAND** all installation and operation instructions as outlined in all manuals thoroughly before installing, operating or servicing this lift.
- ✓ **THOROUGHLY TRAIN ALL EMPLOYEES** in use and care of the lift, using manufacturer's instructions and "Lifting It Right" and "Safety Instructions" supplied with the lift.
- ✓ **NEVER** allow unauthorized or untrained persons to position vehicle/lift or operate lift.
- ✓ **DO NOT USE LIFT** in a manner other than intended. Included but not limited to examples of unapproved uses of the lift would be lifting vehicle by only one side, lifting different axes with a column pair (diagonal lifting), and lifting non-approved items or vehicles.
- ✓ **ALWAYS** become familiar with and understand all lift controls before loading a vehicle onto lift.
- ✓ **NEVER** use on asphalt or soft ground surfaces. Operate lift only on concrete with a minimum strength of 3000 psi and a minimum thickness of 4.5".
- ✓ **MAXIMUM ALLOWED FLOOR SLOPE** is 1/8" per foot side to side of vehicle and 1/4" per foot front to rear of vehicle.
- ✓ **NEVER** use on a suspended floor structure without specific approval from structural engineer.
- ✓ **OBSERVE AND FOLLOW** all safety and warning labels found on the lift and illustrated in the installation and operators manual(s).
- ✓ Electrical components on this lift have internal arcing or sparking parts. To minimize the risk of explosion, **DO NOT** expose lift to flammable vapors or operate lift in the vicinity of open containers of flammable liquids.
- ✓ **ALWAYS** ensure tires are properly inflated before lifting. **NEVER** exceed tire load rating when raising vehicle.
- ✓ **NEVER** raise/lower only one side of a vehicle or vehicle may come in contact with lift columns as vehicle tips.
- ✓ **ALWAYS** lift simultaneously on same axle and **NEVER** stagger between axles.
- ✓ **NEVER** drive over or pinch electrical cables.
- ✓ **NEVER** use if electrical cords are resting in/on standing water, snow or damp floor surfaces.
- ✓ This equipment has an **OPERATING AMBIENT TEMPERATURE RANGE** of 41° - 104°F (5° - 40°C).

COLUMN CONFIGURATIONS

2-COLUMN CONFIGURATION

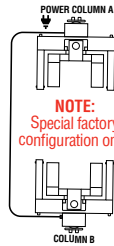

4-COLUMN CONFIGURATION

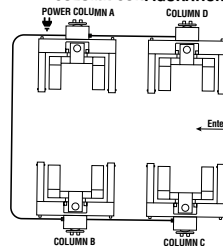

6-COLUMN CONFIGURATION

NOTE:
The electrical communication cables do not have to make a complete loop. It is not necessary to plug the last lift back into the first lift. **SEE DIAGRAM**

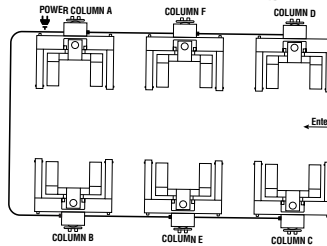

8-COLUMN CONFIGURATION

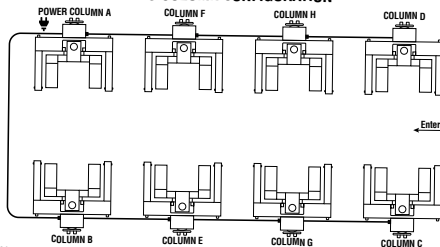

P/N 5905615

⚠ WARNING

- Be sure to observe and follow all safety and warning instructions found on the lift, illustrated on the labels and in the installation and operators manual(s).
- Before attempting to lift any vehicle, be sure that vehicle individual axle weight does not exceed two lift columns combined capacity and adequate overhead clearance is provided to raise vehicle to desired height.
- Make sure lift forks are in secure contact with vehicle tires and parking brake is released on vehicle.
- Adjustable forks must be equally spaced off centerline of lift carriage and adjusted properly to the tire/wheel size.
- Ensure tires are properly inflated before lifting. DO NOT exceed tire load rating when raising vehicle.
- NEVER go under raised vehicle unless all tires are making secure contact with the forks. Lower lift and repeat vehicle and/or lift spotting and loading procedure if necessary.

Failure to read, understand and follow these instructions may cause death or serious injury. Read and understand these instructions before using lift.

QUICK-START OPERATION INSTRUCTIONS

TO RAISE LIFT:

1. After ensuring that the system communication check is complete and the display panel is colored GREEN, press the UP button until all vehicle tires clear the floor. (NOTE: If any single column has an operation fault, the entire set of columns will fail to register and the display panel(s) will be colored RED).
2. Stop and check for secure fork contact with tires at all columns.
3. Continue to raise vehicle to the desired height. (NOTE: If top limit has been set, the lift will automatically stop rising at the desired limit setting.
4. NOTE: While operating the lift, you will observe individual columns slowing down and/or speeding up at various intervals of travel. This is a normal operating characteristic of the system.
5. Press the PARK button to lower lift onto the locking latches.
6. While using lift, avoid excessive rocking of vehicle.

TO LOWER LIFT:

1. Before lowering lift, be sure to remove tool carts, safety stands, etc. from the area and check that all personnel and bystanders remain clear.
2. After ensuring that the system communication check is complete and the display panel is colored GREEN, press the DOWN button to lower lift. NOTE: The RABBIT (🐰) or TURTLE (🐢) settings can be used to control the lowering speed if desired.
3. Observe that all columns are lowering and vehicle remains level.
4. Remain clear of forks and vehicle when lowering. Observe pinch point WARNING decals.
5. Reset the parking brake.
6. Move all lift units away from the vehicle to provide an unobstructed exit before removing the vehicle.
7. NEVER drive vehicle over communication cables.

⚠ WARNING

Clear area if vehicle is in danger of falling.

⚠ WARNING

Remain clear of lift when raising or lowering vehicle.

⚠ CAUTION

Lift to be used by trained operator only.

⚠ CAUTION

Authorized personnel only in lift area.

⚠ WARNING

Locate lift on firm, level surface, preferably concrete.

⚠ WARNING

Be sure intended lifts are moving together evenly.

⚠ CAUTION

When moving lift, be careful to avoid tipping.

⚠ CAUTION

Check for overhead obstructions before raising vehicle.

The messages and pictographs shown are generic in nature and are meant to generally represent hazards common to all automotive lifts regardless of specific style.

Funding for the development and validation of these labels was provided by the Automotive Lift Institute, PO Box 33116 Indialantic, FL. 32903-3116.

They are protected by copyright. Set of labels may be obtained from ALI or its member companies.

1992 by ALI, Inc. ALI/WL400c

⚠ WARNING

All lifting forks must properly engage vehicle tires or supports.

⚠ WARNING

Do not drive over or pinch electrical cables.

SAFETY INSTRUCTIONS

Read operating and safety manuals before using lift.

SAFETY INSTRUCTIONS

Proper maintenance and inspection is necessary for safe operation.

⚠ WARNING

Keep feet clear of lift while lowering.

The messages and pictographs shown are generic in nature and are meant to generally represent hazards common to all automotive lifts regardless of specific style.

Funding for the development and validation of these labels was provided by the Automotive Lift Institute, PO Box 33116 Indialantic, FL. 32903-3116.

They are protected by copyright. Set of labels may be obtained from ALI or its member companies.

ALI/WL400w

SAFETY INSTRUCTIONS

Do not operate a damaged lift.

The messages and pictographs shown are generic in nature and are meant to generally represent hazards common to all automotive lifts regardless of specific style.

Funding for the development and validation of these labels was provided by the Automotive Lift Institute, PO Box 33116 Indialantic, FL. 32903-3116.

They are protected by copyright. Set of labels may be obtained from ALI or its member companies.

1992 by ALI, Inc. ALI/WL400s

Safe Lift Operation

Automotive and truck lifts are critical to the operation and profitability of your business. The safe use of this and other lifts in your shop is critical in preventing employee injuries and damage to customer's vehicles. By operating lifts safely you can ensure that your shop is profitable, productive and safe. Safe operation of automotive lifts requires that only trained employees should be allowed to use the lift.

TRAINING SHOULD INCLUDE, BUT NOT BE LIMITED TO:

- ◆ Proper positioning of the columns with respect to the vehicle.
- ◆ Use of the operating controls.
- ◆ Understanding the lift capacity.
- ◆ Proper use of jack stands or other load supporting devices.
- ◆ Proper use, understanding and visual identification of safety lock devices and their operation.
- ◆ Reviewing the safety rules.
- ◆ Proper housekeeping procedures. (Lift area should be free of grease, oil, tools, equipment, trash, and other debris.)
- ◆ A daily inspection of the lift should be completed prior to its use. Safety devices, operating controls, lift arms and other critical parts should be inspected prior to using the lift.
- ◆ All maintenance and repairs of the lift should be completed by following the manufacturer's requirements. Lift repair parts should meet or exceed OEM specifications. Repairs should only be completed by a qualified lift technician.
- ◆ The vehicle manufacturer's recommendations should be used for spotting and lifting the vehicle.

LIFT OPERATION SAFETY

- ◆ It is important that you know the load limit. Be careful that you do not overload the lift. If you are unsure what the load limit is, check the data plate found on one of the lift columns or contact the manufacturer.
- ◆ Always make sure you have proper overhead clearance. Additionally, check that attachments, (vehicle signs, campers, antennas, etc.) are not in the way.
- ◆ Be sure that prior to the vehicle being raised, the doors, trunk, and hood are closed securely.
- ◆ Prior to being raised, make sure there is no one standing closer than six feet from the lift.
- ◆ After positioning the columns on the vehicle, set the emergency brake, make sure the ignition is off, the doors are closed, and overhead obstructions are cleared.
- ◆ Double check that the wheel forks are in position and then when the lift is raised observe the forks.
- ◆ Put pads or adapters in the right position under the contact points that have been recommended.
- ◆ The lift should be raised just until the vehicle's wheels are about one foot off the ground. If contact with the vehicle is uneven or it appears that the vehicle is not sitting secure, carefully lower the lift and readjust.
- ◆ Always consider potential problems that might cause a vehicle to slip, i.e., heavy cargo, undercoating, etc.
- ◆ Pay attention when walking under a vehicle that is up on the hydraulic lift.



- ◆ **DO NOT** leave the controls while the lift is still in motion.
- ◆ **DO NOT** stand directly in front of the vehicle or in the bay when vehicle is being loaded or driven into position.
- ◆ **DO NOT** go near vehicle or attempt to work on the vehicle when being raised or lowered.
- ◆ **REMAIN CLEAR** of lift when raising or lowering vehicle.
- ◆ **DO NOT** rock the vehicle while on the lift or remove any heavy component from vehicle that may cause excessive weight shift.
- ◆ **DO NOT** lower the vehicle until people, materials, and tools are clear.
- ◆ **ALWAYS ENSURE** that the safeties are engaged and carriages are lowered on to the safeties before any attempt is made to work on or near vehicle.
- ◆ Some vehicle maintenance and repair activities may cause the vehicle to shift. Follow the manufacturer's guidelines when performing these operations. The use of jack stands or alternate lift points may be required when completing some repairs.
- ◆ **READ AND UNDERSTAND** all safety warning procedures before operating lift.
- ◆ **KEEP HANDS AND FEET CLEAR.** Remove hands and feet from any moving parts. Keep feet clear of lift when lowering. Avoid pinch points.
- ◆ **ONLY TRAINED OPERATORS** should operate this lift. All non-trained personnel should be kept away from work area. Never let non-trained personnel come in contact with, or operate lift.
- ◆ **USE LIFT CORRECTLY.** Use lift in the proper manner. Never use lifting adapters other than what is approved by the manufacturer.
- ◆ **DO NOT** override self-closing lift controls.
- ◆ **CLEAR AREA** if vehicle is on danger of falling.
- ◆ **STAY ALERT.** Watch what you are doing. Use common sense. Be aware.
- ◆ **CHECK FOR DAMAGED PARTS.** Check for alignment of moving parts, breakage of parts or any condition that may affect its operation. Do not use lift if any component is broken or damaged.
- ◆ **NEVER** remove safety related components from the lift. Do not use lift if safety related components are damaged or missing.
- ◆ When the lift is being lowered, make sure everyone is standing at least six feet away.
- ◆ Be sure there are no jacks, tools, equipment, left under the lift before lowering.
- ◆ Always lower the vehicle down slowly and smoothly.

TROUBLESHOOTING AND FAULTS



DO NOT PERFORM ANY MAINTENANCE OR INSTALLATION OF ANY COMPONENTS WITHOUT FIRST ENSURING THAT ELECTRICAL POWER HAS BEEN DISCONNECTED AT THE SOURCE OR PANEL AND CANNOT BE RE-ENERGIZED UNTIL ALL MAINTENANCE AND/OR INSTALLATION PROCEDURES ARE COMPLETED.

Be sure all PLC from the columns are in the RUN position. (See Figure Below).

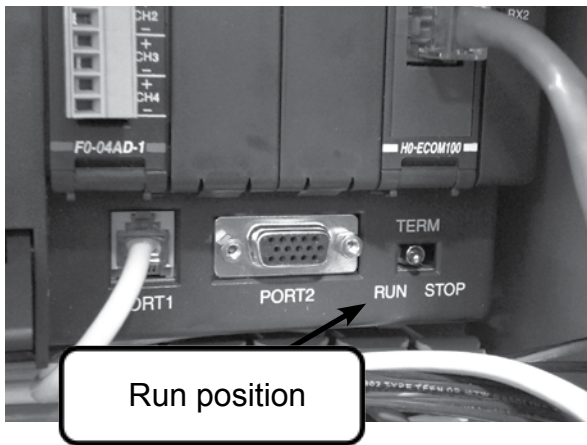

During operation of the PCL-18 you may encounter different type of errors. The screen on the Control Panels will turn red and display the fault condition (with the exception of the At Top Limit Fault). Generally these fault warnings can be cleared by pressing the RESET button or F3. The following is a list of these faults and their solutions:

-Out of Tolerance Fault- This fault occurs whenever the height of at least 2 columns are out of the factory set tolerance limit. Various conditions can result in this fault:

- One Carriage may miss the safety while setting the PARK. Press the RESET button or F3 then determine which Column or Columns are out of tolerance and either raise or lower that Carriage in Single mode to the same height as the others and reattempt to Park.
- If an Out of Tolerance Fault is detected and all of the Carriages are lowered to the ground, calibrate the system or turn the power switch on Column A to Off, wait a few seconds and turn the power back on. (See figures 11.1 and 11.2)

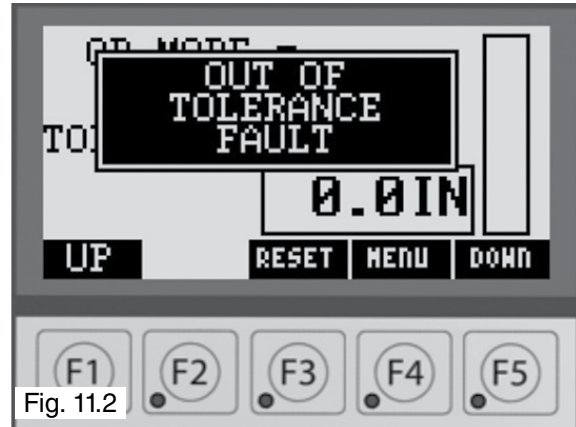
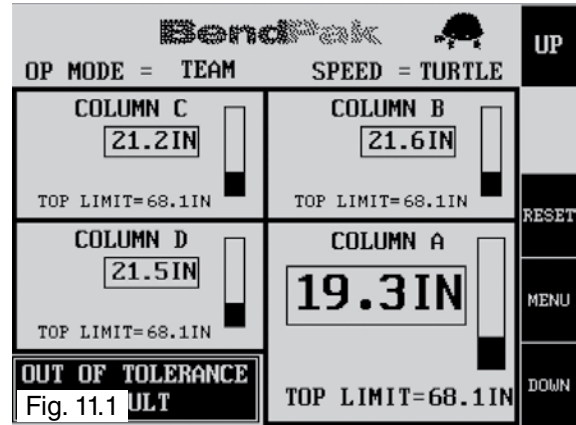

Column A
Slave Columns
No Motion Fault- This fault is present when the system detects no movement when UP or DOWN has been pressed. Possible causes could include:

- The lift being lowered in Turtle mode with no weight loaded.
- Not enough grease in the rollers or on the post where the Carriage slide blocks slide.
- Not enough fluid in the Hydraulic Power Unit.
- Air may be trapped in the system.

(See Fig 11.3 & 11.4)

Column A

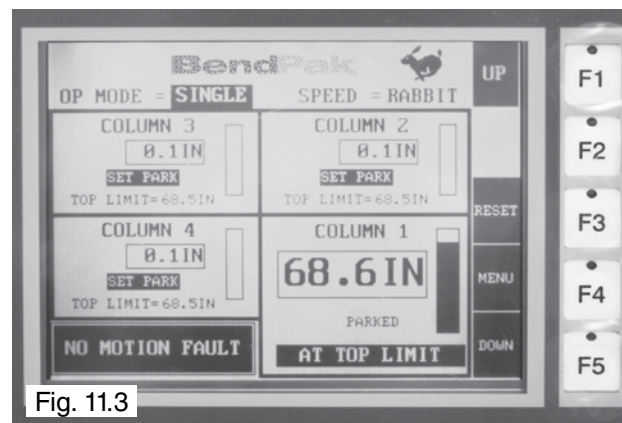



Fig. 11.4

Slave Columns

At Top Limit Fault- This is a normal indicator of the lift that alerts the operator that the lift has reached the maximum allowable height set in the Menu options. However, it can sometimes be detected when all Carriages are lowered completely. This usually occurs due to improper calibration.

-Bleed the cylinder(s), Calibrate the system and try again.
(See Fig 11.5 & 11.6)

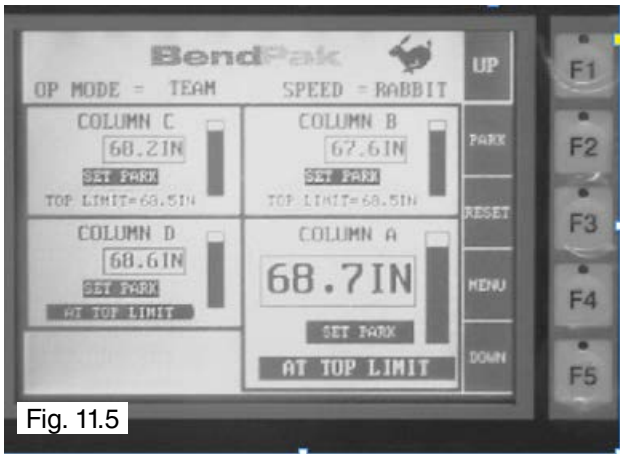

Fig. 11.5

Column A

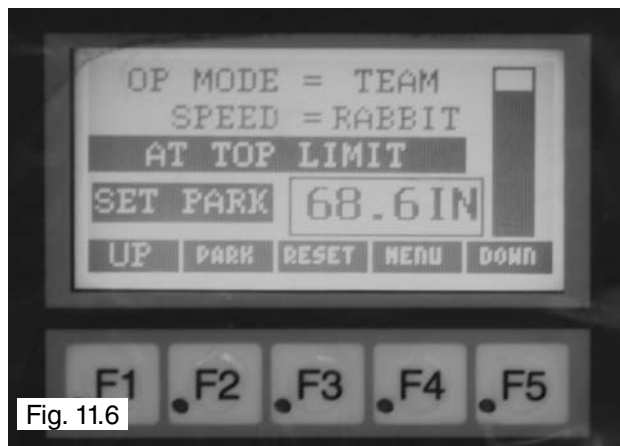

Fig. 11.6

Slave Columns

E-Stop or No Communication Fault- Whenever the emergency stop button is pressed on any Column all motion of the lift ceases and prevents the function buttons of all Control Panels from operating the lift until the emergency button is released and the fault cleared.

-Alternatively, if any Control Panel stops sending information to the main PLC or if a cable becomes disconnected the same fault will be detected.

- Check the Emergency Stop buttons.
- Check cable connections.
- Check power connections.
- Call factory/electrician.

(See Fig 11.7 & 11.8)

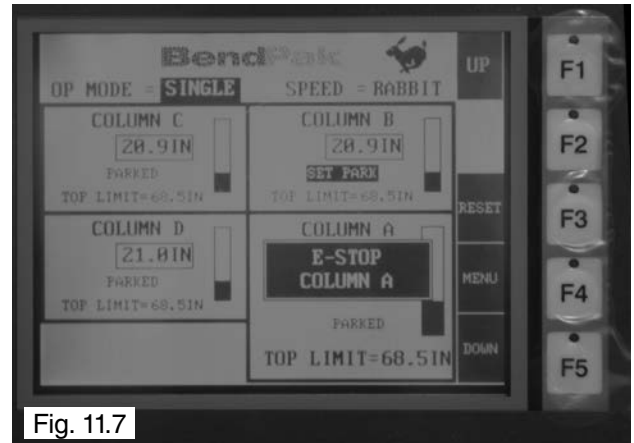

Fig. 11.7

Column A



Fig. 11.8

Slave Columns

String Pot Fault- If the PLC system ever loses the signal from a string pot this fault will be displayed.

-Check fuses F3 and F33. If blown, replace.

Once fuses are replaced, reconnect and turn the system on. When the system powers up an Out of Tolerance fault will be detected. Clear the fault as stated previously and continue operation.

-Check string pot string

If string has become disconnected from the bottom of the carriage, reattach and continue operating. If the string is broken call factory for replacement and discontinue use until new string pot is installed.

(See Fig 11.9 & 11.10)

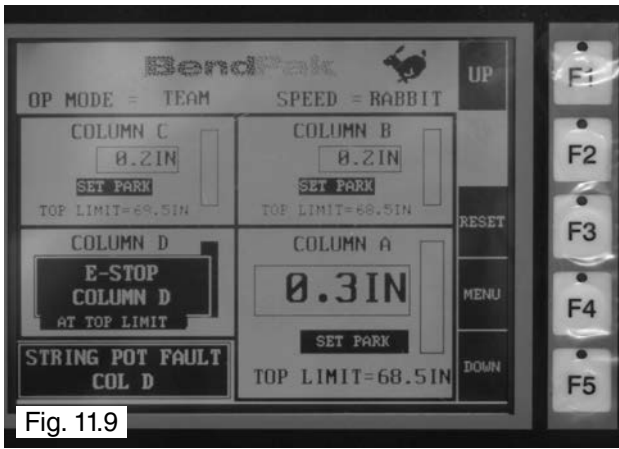

Fig. 11.9

Column A

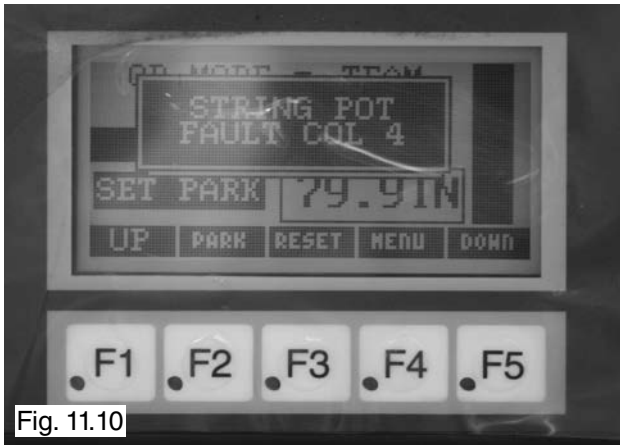

Fig. 11.10

Slave Columns

Other issues:

Column A is in the ON position but lift will not power on:

- Check fuses F1 and F2. If blown, replace.
- Check power connections.
- Call factory/electrician.

Lift powered but Control Panels do not light:

- Check power connections.
- Check all cable and wire connections between PLC, controls and displays.
- Call factory/electrician

Manual Override: If at any time a fault condition is detected and cannot be cleared as per instruction and a vehicle is stranded in the air, manually lower each carriage by releasing the pressure relief valve on each power unit. Pull out and turn 1/4 turn.

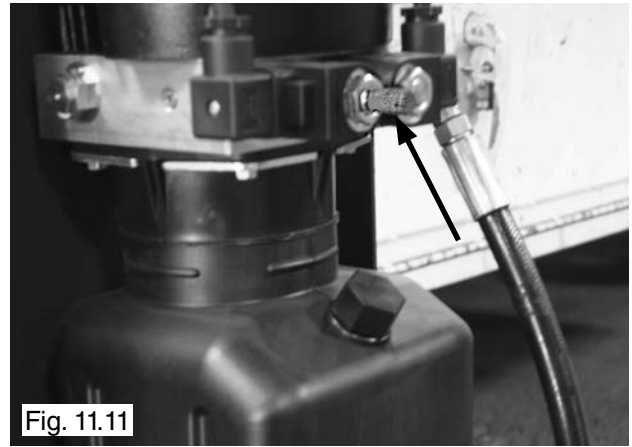

Fig. 11.11



Please read the entire manual prior to installation. Do not operate this machine until you have read and understood all of the Danger, Warning and Caution alerts in this manual.



For additional copies or further information, contact:

BendPak Inc.

1645 Lemonwood Dr.
 Santa Paula, CA. 93060
 1-805-933-9970

www.bendpak.com

DUE TO CONTINUOUS PRODUCT IMPROVEMENTS, BENDPAK/RANGER RESERVES THE RIGHT TO MAKE SPECIFICATION CHANGES WITHOUT PRIOR NOTIFICATION. PLEASE, CONTACT BENDPAK/RANGER FOR UPDATED INFORMATION.

LIFT WILL NOT RAISE

POSSIBLE CAUSE

1. Air in oil, (1,2,6,11)
2. Cylinder binding, (7)
3. Cylinder leaks internally, (7)
4. Motor run backward under pressure, (9)
5. Lowering valve leaks, (3,8,9)
6. Motor runs backwards, (5,9,12)
7. Pump damaged, (8,9)
8. Pump won't prime, (1,6,8,9,10,11,12)
9. Relief valve leaks, (8,9)
10. Voltage to motor incorrect, (5,9,12)

REMEDY

1. Check for proper oil level.
2. Bleed cylinders.
3. Dirty oil
4. Tighten all fasteners.
5. Check motor is wired correctly.
6. Oil seal damaged or crooked
7. See Installation Manual
8. Replace with new part
9. Return unit for repair
10. Check pump-mounting bolts
11. Inlet screen clogged
12. Check wall outlet voltages and wiring

INSTRUCTION

- The oil level should be up to the FILL screw in the reservoir with the lift all the way down.
- See Installation Manual.
- Use clean 10-WT hydraulic oil or Dexron-III automatic transmission fluid only. If fluid/oil is contaminated, replace with clean fluid/oil and clean entire system.
- Tighten fasteners to recommended torques.
- Compare wiring of motor to electrical diagram on drawing.
- Replace oil seal around pump shaft.
- Consult Lift Manufacturer.
- Replace with new part.
- Return unit for repair.
- Bolts should be 15 to 18 ft. lbs.
- Clean inlet screen or replace.
- Make sure unit and wall outlet are wired properly.

**OUR LIFTS ARE SHIPPED WITHOUT OIL.
ADD OIL TO POWER UNIT TANK BEFORE USE.**

MOTOR WILL NOT RUN

POSSIBLE CAUSE

1. Fuse blown, (1,2,3,4,5)
2. Motor burned out, (1,2,3,4,6)
3. Voltage to motor incorrect, (1,2,8)

REMEDY

- | REMEDY | INSTRUCTION |
|---|---|
| 1. Check for correct voltage | Compare supply voltage with voltage on motor name tag. Check that the wire is sized correctly. N.E.C. table 310-12 requires AWG 10 for 25 Amps. |
| 2. Check motor is wired correctly | Compare wiring of motor to electrical diagram on drawing. |
| 3. Don't use extension cords | According to N.E.C. : " The size of the conductors... should be such that the voltage drop would not exceed 3% to the farthest outlet for power..." Do not run motor at 115 VAC – damage to the motor will occur. |
| 4. Replace with new part | Replace with new part. |
| 5. Reset circuit breaker/fuse | Reset circuit breaker/fuse. |
| 6. Return unit for repair | Return unit for repair. |
| 7. See Installation Manual | See Installation Manual. |
| 8. Check wall outlet voltage and wiring | Make sure unit and wall outlet is wired properly. Motor must run at 208/230 VAC 3 phase. |

LIFT LOWERS SLOWLY OR NOT AT ALL

POSSIBLE CAUSE

1. Cylinders binding, (1)
2. Release valve clogged, (5,4,2,3)

REMEDY

- | REMEDY | INSTRUCTION |
|--------------------------------------|--|
| 1. See Installation Manual | Consult Lift Manufacturer. |
| 2. Replace with new part | Replace with new part. |
| 3. Return for repair | Return for repair. |
| 4. Check oil. | Use clean 10-WT hydraulic oil or Dexron-III automatic transmission fluid only. If fluid/oil is contaminated, replace with clean fluid/oil and clean entire system. |
| 5. Clean release valve | Wash release valve in solvent and blow out with air. |

IMPORTANT

If vehicle becomes stranded in the air, follow all operation instructions as shown on pages 25, & 33-35. If after observing that all mechanical locks are released and the lift still fails move following all standard operating procedures, immediately stop using the lift and contact factory or factory approved service center for further instructions.

WILL NOT RAISE LOADED LIFT

POSSIBLE CAUSE

1. Air in oil, (1,2,3,4)
2. Cylinder binding, (5)
3. Cylinder leaks internally, (5)
4. Lift overloaded, (5,6)
5. Lowering valve leaks, (1,5,7,8)
6. Motor runs backwards, (8,9,11)
7. Pump damaged, (5,8)
8. Pump won't prime, (1,2,3,4,5,8,10)
9. Relief valve leaks, (5,7,8)
10. Voltage to motor incorrect, (5,9,11)

REMEDY

1. Check oil level The oil level should be up to the fill screw in the reservoir with the lift all the way down.
2. Check/Tighten inlet tubes Replace inlet hose assembly.
3. Oil seal damaged or cocked Replace oil seal and install.
4. Bleed cylinders See Installation Manual.
5. See Installation Manual Consult Lift Manufacturer.
6. Check vehicle weight Compare weight of vehicle to weight limit of the lift.
7. Replace with new part Replace with new part.
8. Return unit for repair Return unit for repair.
9. Check motor is wired correctly Compare wiring of motor to electrical diagram on power unit drawing.
10. Inlet screen clogged Clean inlet screen or replace.
11. Check wall outlet voltage and wiring Make sure unit and wall outlet is wired properly.

INSTRUCTION

**OUR LIFTS ARE SHIPPED WITHOUT OIL.
ADD OIL TO POWER UNIT TANK BEFORE USE.**

LIFT WILL NOT STAY UP

POSSIBLE CAUSE

1. Air in oil, (1,2,3)
2. Check valve leaks, (5)
3. Cylinders leak internally, (6)
4. Lowering valve leaks, (1,4,5,6)
5. Leaking fittings, (7)

REMEDY

- | REMEDY | INSTRUCTION |
|---|---|
| 1. Check oil level | The oil level should be up to the fill screw in the reservoir with the lift all the way down. |
| 2. Oil seal damaged and cocked | Replace oil seal around pump shaft. |
| 3. Bleed cylinder | Refer to Installation Manual. |
| 4. Replace with new valve | Replace with new valve. |
| 5. Return unit for repair | Return unit for repair. |
| 6. See Installation Manual | Consult Lift Manufacturer. |
| 7. Check complete hydraulic system for leaks. | Tighten all hydraulics fittings and inspects all hoses. |

**OUR LIFTS ARE SHIPPED WITHOUT OIL.
ADD OIL TO POWER UNIT TANK BEFORE USE.**

INSTALLATION FORM

Customer Name:		Date of Installation:
Company Name:		
Street Address:		
City:	State:	Zip:
Phone:	Fax:	

Pre-Install Agreement

I, (the undersigned) acting as the owner of the business listed above assume responsibility for any permits required, either state or county mandated, related to the installation and/or operation of this equipment. I assume responsibility for the concrete floor and condition thereof, now or later, where the above equipment model(s) are installed. I will assume all liability for losses, damages (including loss of use), expenses, demands, claims, and judgments in connection with or arising out of any personal injury or alleged damage to property, sustained or alleged to have been sustained in connection with, or to have arisen out of the condition and/or drilling of the concrete near or adjacent to the equipment model(s) listed above. If my employee(s) offer assistance of any kind during installation of the above equipment model(s) I hold the manufacturer and installation company harmless of all liability for losses, damages, expenses, claims, and judgments in connection with or arising out of any personal injury or alleged damage to property, sustained or alleged to have been sustained in connection with the installation of the above equipment model(s).

I understand that the lifts above are supplied with concrete fasteners meeting the criteria of the American National Standard "Automotive Lifts - Safety Requirements for Construction, Testing, and Validation" ANSI/ALI ALCTV-1998, and that I will be responsible for all charges related to any special regional structural and/or seismic anchoring requirements specified by any other agencies and/or codes such as the Uniform Building Code (UBC) and/or International Building Code (IBC).

Customer Signature:	Print Name:	Date:
---------------------	-------------	-------

Post-Installation Check-Off

- | | |
|---|---|
| <input type="checkbox"/> Base and Columns Properly Shimmed And Stable | <input type="checkbox"/> Lubrication of Critical Components |
| <input type="checkbox"/> Anchor Bolts Tightened | <input type="checkbox"/> Lift Adapters |
| <input type="checkbox"/> Runways Properly Attached and Secured | <input type="checkbox"/> Check For Overhead Obstructions |
| <input type="checkbox"/> Electric Power Supply Confirmed | <input type="checkbox"/> Runways Level |
| <input type="checkbox"/> Cables / Chains Adjusted Properly | <input type="checkbox"/> All Screws, Bolts, and Pins Secured |
| <input type="checkbox"/> Safety Locks Functioning Properly | <input type="checkbox"/> Surrounding Area and Lift Clean In Appearance |
| <input type="checkbox"/> Check For Hydraulic Leaks | <input type="checkbox"/> Proper Operation, Maintenance and Safety Explained |
| <input type="checkbox"/> Oil Level | <input type="checkbox"/> Operation and Safety Manual(s) Left at Site |

I, (the undersigned) confirm that the above installation procedure(s) were completed. I understand that I will be responsible for maintaining this equipment as outlined in the accompanied **Installation and Operation Manual** and **ANSI/ALI ALOIM Safety Requirements for Operation, Inspection and Maintenance**. I understand that personal injury and/or damage to property can occur if the above equipment model(s) are not maintained or used improperly and take full responsibility for training my employees on proper use and maintenance of this equipment. I hold the manufacturer and installation company harmless of all liability for losses, damages (including loss of use), expenses, demands, claims, and judgments in connection with or related to improper use, improper training, or lack of required maintenance. I understand that the warranty does not cover replacement of parts worn or damaged due to normal use or lack of required maintenance

Customer Signature:	Print Name:	Date:
---------------------	-------------	-------

Installer Signature:	Print Name:	Date:
----------------------	-------------	-------

Installer Company Name:

Street Address:

City:	State:	Zip:
Phone:	Phone (Other):	

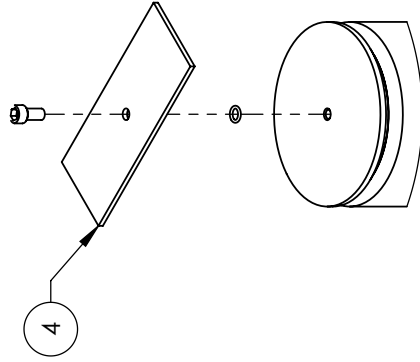
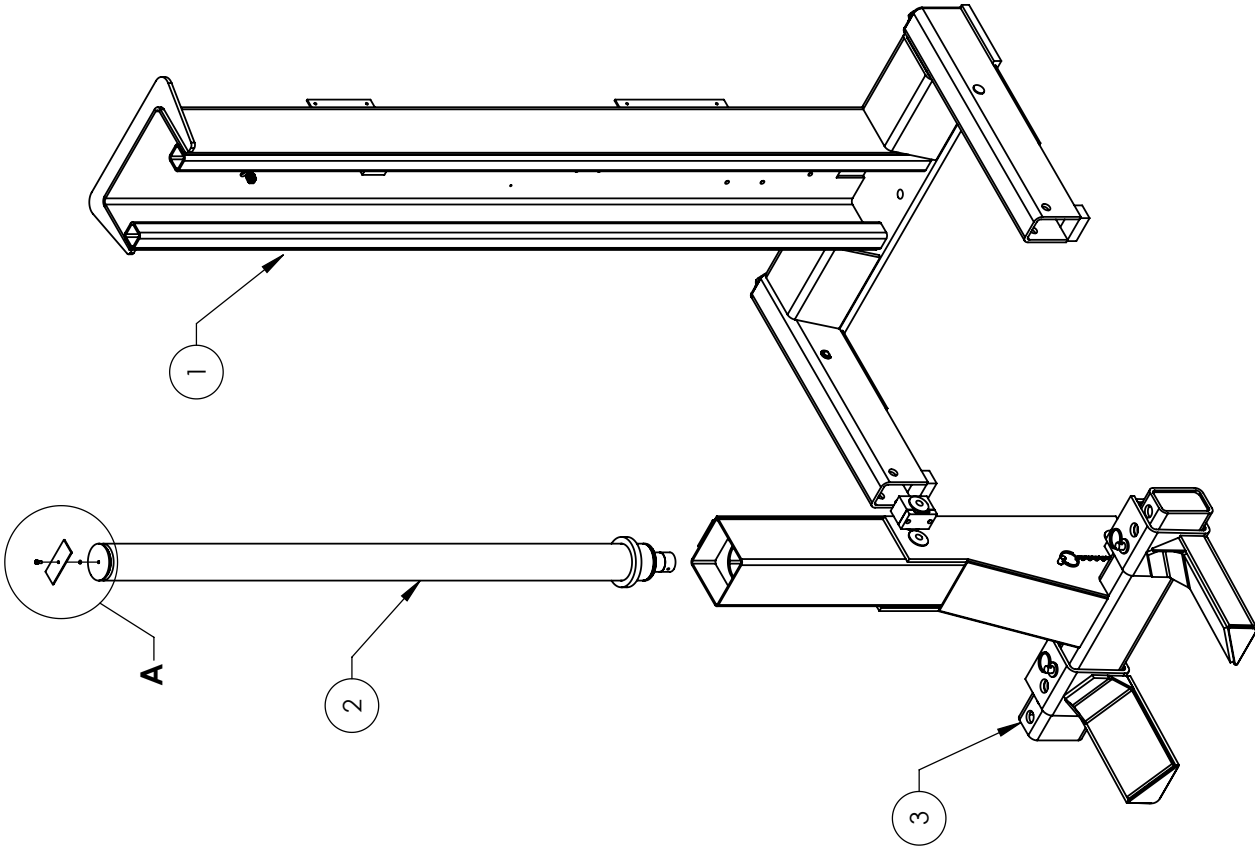

DETAIL A
SCALE 1 : 4

ITEM NO	PART NUMBER	DESCRIPTION	QTY	REV
1	521.5014	PCL-18 POST ASSEMBLY	1	K
2	5502304	CYLINDER ASSEMBLY Ø3.5 x 69	1	B
3	521.5034	PCL-18 CARRIAGE ASSEMBLY	1	J
4	5701103	PCL-18 CYLINDER STOPPER	1	A

DO NOT SCALE DRAWING		NAME	DATE
DRAWN	TM	07/14/2009	
CHECKED	VB	03/20/2015	
THIRD ANGLE PROJECTION			
<small>PROPRIETARY AND CONFIDENTIAL THE SOLE PROPERTY OF BENDPAK INC. ANY REPRODUCTION IN PART OR AS A WHOLE WITHOUT PERMISSION OF BENDPAK INC. IS PROHIBITED.</small>			
		TITLE: PCL-18 COLUMN SUPERSTRUCTURE	
DIMENSIONS ARE IN MM		SIZE	DWG. NO.
		A	5245121
		REV	P
		SCALE:	1:20
			SHEET 1 OF 1

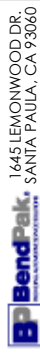

NEXT ASSEMBLY
5260130
5260330
5260331
5260333

NOTE: UNLESS OTHERWISE SPECIFIED.
 1. SEE SHIPPING INSTRUCTIONS FOR FINAL PACKAGING
 2. ASSEMBLE ITEMS AS SHOWN

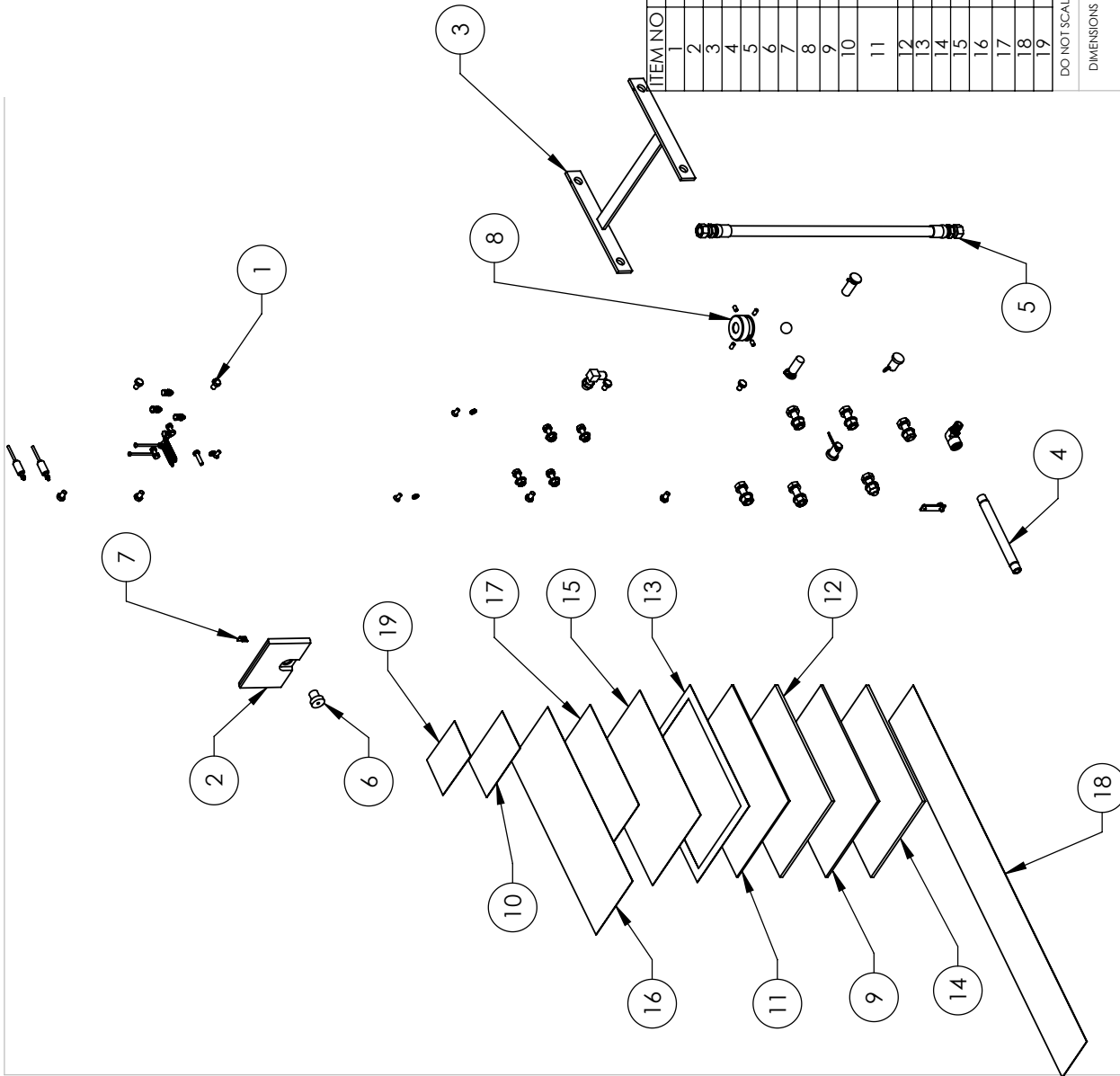

ITEM NO	PART NUMBER	DESCRIPTION	QTY	REV
1	5174499	PCL-18 PARTS BAG	1	F
2	5600704	PCL-18 SAFETY BLOCK WELDMENT	1	B
3	5600278	PCL-18 TOW CART TIE PLATE WELDMENT	1	C
4	5756113	PCL-18 HYDRAULIC TUBE	1	B
5	5570872	PCL-18 HYD. HOSE ASSY Ø10 x 850mm DS	1	B
6	5746615	PCL-18 SAFETY PIVOT PIN	1	C
7	5721099	PCL-18 SOLENOID TRIP BRACKET	1	C
8	5746257	PCL-18 WHEELED JACK RETAINER RING	1	B
9	5900147	SAFETY MANUAL ALL / SM 93-1	1	-
10	5900151	BENDPAK #90 WARRANTY CARD	1	-
11	5900152	ALIGN OIM OPERATION INSPECTION & MAINTENANCE	1	-
12	5900280	AL/TP FRAME ENGAGING TIPS GUIDE	1	-
13	5905151	SAFETY TIPS CARD AL-ST 90	1	-
14	5900176	PCL-18 INSTALLATION MANUAL	1	-
15	5905580	PCL-18 ALL SAFETY LABEL KIT	1	-
16	5905615	PCL-18 WARNING LABEL	1	-
17	5905620	PCL-18 INSTRUCTIONS LABEL	1	-
18	5905105	BP LABEL	1	-
19	5905675	MAX CAP NRTL DANGER 18K	1	A

DO NOT SCALE DRAWING

DRAWN TM 07/14/2009

CHECKED VB 03/12/2015

THIRD ANGLE PROJECTION

NAME DATE

1645 LEMONWOOD DR.
BendPak SANTA PAULA, CA 93060

TITLE: PCL-18 PARTS BOX, PRIMARY COLUMN

SIZE DWG. NO. 5250221

REV H

SCALE: 1:12

SHEET 1 OF 1

PROPRIETARY AND CONFIDENTIAL
 THE INFORMATION CONTAINED IN THIS DRAWING IS THE SOLE PROPERTY OF BENDPAK INC. ANY REPRODUCTION OR TRANSMISSION IN ANY FORM OR BY ANY MEANS WITHOUT THE WRITTEN PERMISSION OF BENDPAK INC. IS PROHIBITED.

MATERIAL: ---

SIZE: ---

NEXT ASSEMBLY 5260130

NOTE: UNLESS OTHERWISE SPECIFIED, SEE SHIPPING INSTRUCTIONS FOR FINAL PACKAGING

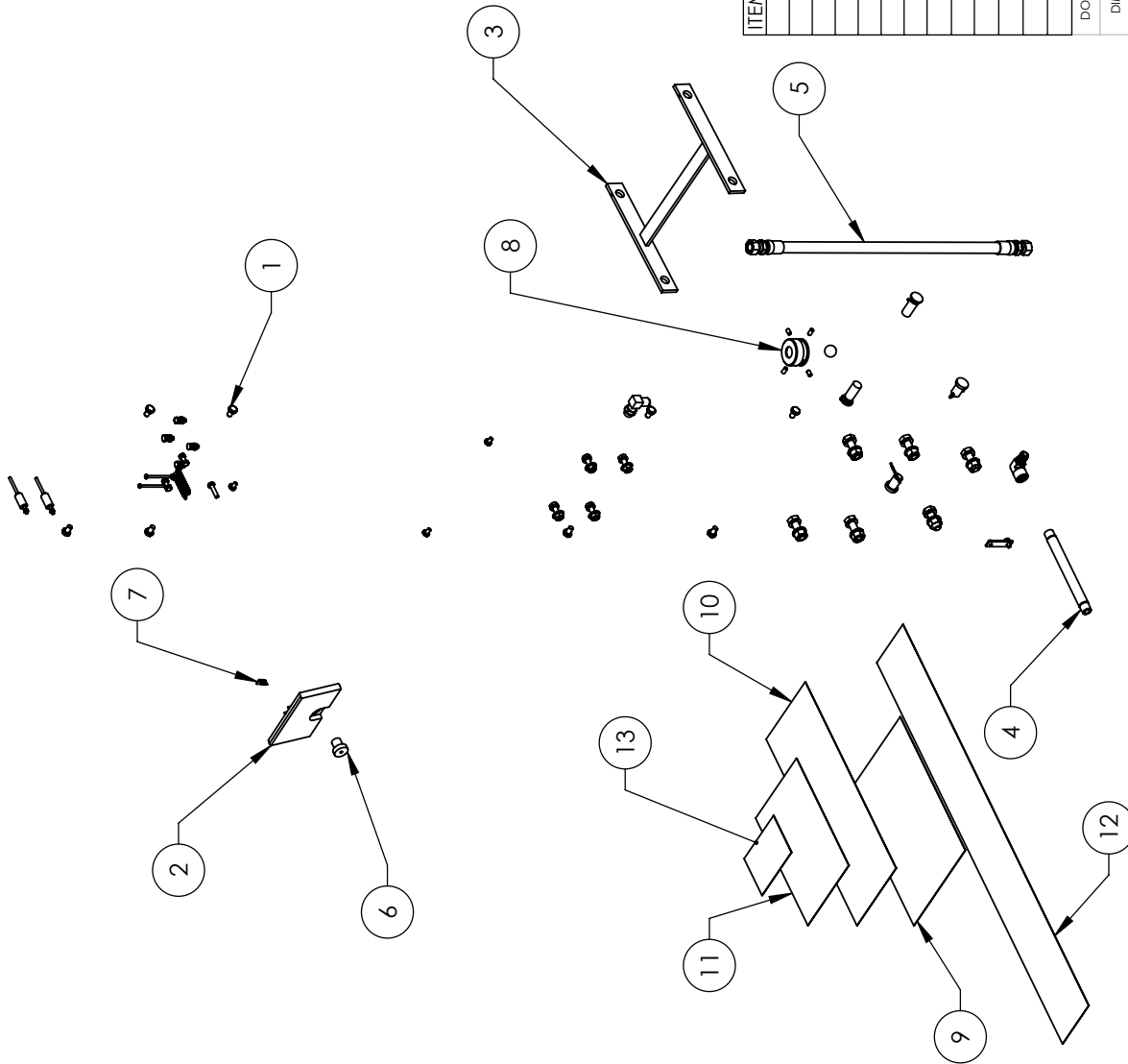

ITEM NO	PART NUMBER	DESCRIPTION	QTY	REV
1	5174499	PCL-18 PARTS BAG	1	F
2	5600704	PCL-18 SAFETY BLOCK WELDMENT	1	B
3	5600278	PCL-18 TOW CART TIE PLATE WELDMENT	1	C
4	5756113	PCL-18 HYDRAULIC TUBE	1	B
5	5570872	PCL-18 HYD. HOSE ASSY Ø10 x 850mm DS	1	B
6	5746615	PCL-18 SAFETY PIVOT PIN	1	C
7	5721099	PCL-18 SOLENOID TRIP BRACKET	1	C
8	5746257	PCL-18 WHEELED JACK RETAINER RING	1	B
9	5905580	PCL-18 ALI SAFETY LABEL KIT	1	-
10	5905615	PCL-18 WARNING LABEL	1	-
11	5905620	PCL-18 INSTRUCTIONS LABEL	1	-
12	5905105	BP LABEL	1	A
13	5905675	MAX CAP NRTL DANGER 18K	1	A

DO NOT SCALE DRAWING

DIMENSIONS ARE IN MM

THIRD ANGLE PROJECTION

NAME: TM DATE: 11/02/2011

CHECKED: VB DATE: 03/12/2015

1645 LEMONWOOD DR.
BendPak SANTA PAULA, CA 93060
 BENDPAK.COM

TITLE: PCL-18 PARTS BOX, SECONDARY COLUMN

SIZE DWG. NO. A 5250350 REV F

SCALE: 1:12 SHEET 1 OF 1

PROPRIETARY AND CONFIDENTIAL
 THE INFORMATION CONTAINED IN THIS DRAWING IS THE SOLE PROPERTY OF BENDPAK INC. ANY REPRODUCTION OR TRANSMISSION OF THIS DRAWING WITHOUT THE WRITTEN PERMISSION OF BENDPAK INC. IS PROHIBITED.

MATERIAL: ---

SIZE: ---

NEXT ASSEMBLY: 5620330, 5620331, 5620333

NOTE: UNLESS OTHERWISE SPECIFIED, SEE SHIPPING INSTRUCTIONS FOR FINAL PACKAGING

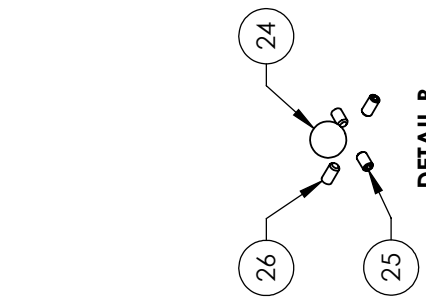

**DETAIL B
SCALE 1:4**

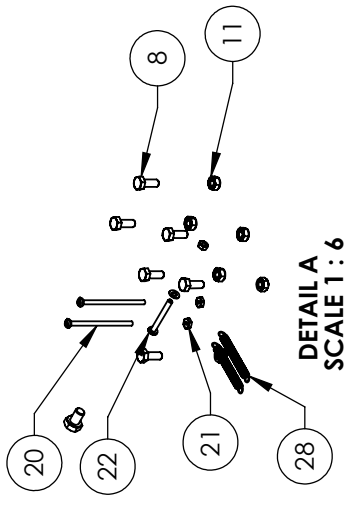
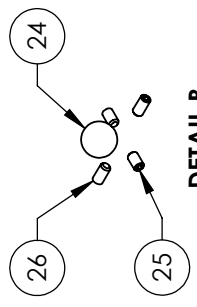

**DETAIL A
SCALE 1:6**

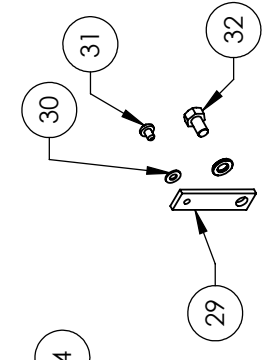

**DETAIL C
SCALE 1:4**

ITEM NO	PART NUMBER	DESCRIPTION	QTY	REV
1	5530079	BPHS M6 x 1.0 x 1.0	3	
2	5535354	NUT M12 x 1.75	6	
3	5530076	HHB M12 x 1.75 x 35mm	6	
4	5549201	WASHER M12 SPRING LOCK	6	
5	5545347	WASHER M12 FLAT WASHER	6	
6	5530756	HHB M6 x 1 x 25	1	
7	5530010	HHB M8 x 1.25 x 25	4	
8	5530019	HHB M6 x 1 x 16	4	
9	5545021	WASHER M8 x Ø20 FLAT	4	
10	5545022	WASHER M8 x Ø15 SL	4	
11	5535357	NUT M6 x 1.0 INL	4	
12	5535001	HHB M8 x 1.25 x 12	4	A
13	5530025	HHB M8 x 1.25 x 12	8	
14	5505117	PCL-18 TOW ANCHOR PIN	2	B
15	5530157	SSS M4 x 0.7 x 10	2	
16	5505109	PCL-18 TOW CARTLIE PIN	2	B
17	5550109	FIG ELB-06 JIC x 06 F NPT	2	
18	5550183	FIG ELB-06 JIC 06 ORB	1	
19	5549005	M6 FLAT WASHER	4	
20	5530147	BHS 6-32 x 2.5	2	
21	5535190	HN 6-32	2	
22	5530252	BPHS M4 x 0.7 x 35	1	
23	5535010	NUT M4 x 0.7	5	
24	5745215	PCL-18 WHEELED JACK PIVOT BEARING	1	B
25	5530057	SSS M5 x 0.8 x 10	2	
26	5530099	SSS M2 x 1.0 x 12	2	
27	5505335	HAIR PIN #203. Ø0.093" x 1.5/8"	2	
28	5540041	PULL SPRING Ø6.35 x 50mm	2	A
29	5736532	PCL-18 STRING POT LINKAGE	2	A
30	5545009	WASHER Ø4.3 x Ø9mm x 0.8mm	2	
31	5530320	BPHS M4 x 0.7 x 6	1	
32	5530181	HHB M6 x 1.0 x 10	1	
33	5530233	M4 x 0.7 x 80 THREADED ROD	2	
34	5746294	PCL-18 STRING POT MOUNTING SPACER	2	A

DO NOT SCALE DRAWING
DIMENSIONS ARE IN MM

DRAWN TM 07/14/2009
CHECKED MIM 02/18/2013

THIRD ANGLE PROJECTION

PROPERTY AND CONFIDENTIAL
THE INFORMATION CONTAINED IN THIS DRAWING IS
THE SOLE PROPERTY OF BENDPAK INC. ANY
REPRODUCTION OR TRANSMISSION WITHOUT
THE WRITTEN PERMISSION OF BENDPAK INC. IS
PROHIBITED.

MATERIAL: ---
SIZE: ---

NEXT ASSEMBLY
5250221

1645 LEMONWOOD DR.
SANTA PAULA, CA 93060

TITLE: PCL-18 PARTS BAG

SIZE DWG. NO. 5174499
REV F

SCALE: 1:12 SHEET 1 OF 1

**NOTE: UNLESS OTHERWISE SPECIFIED,
1. SEE SHIPPING INSTRUCTIONS FOR FINAL PACKAGING**



Brand: BendPak
Model: MLS-18
Description: Mobile High-Lift Jack Stand

The MLS-18 is a support stand to be used to support raised heavy duty vehicles, to facilitate maintenance and inspection procedures. The support stand is designed to be used in sets of 4, 6 or 8 and must be placed under a level, raised vehicle, at the support points designated by the vehicle manufacturer.

- Each MLS-18 has a maximum rated capacity of 18,000 pounds.
- Tripod design; each of the three (3) legs will evenly distribute the supported weight.
- Each leg is equipped with an 11" square inch floor pad.
- Can be easily moved and placed under a vehicle by means of two 3" diameter wheels.
- Equipped with a fold-away transport handle.
- Center tube is spring assisted to facilitate adjustment of the stand.
- Adjustable from 48.75 to 74.5"
- 9 pin positions
- 1" diameter self-locking ACME screw for fine adjustment of the stand height



Specifications

- Minimum height 48.75"
- Maximum height 74.5"
- Number of pin positions 9
- Screw fine adjustment 3.5" / Adjustment Capability
- Stroke 25.75 inches
- Base diameter 32"
- Wheels / Diameter 3"
- Top Pad Diameter 6"
- Stand capacity 18,000 Lbs.

BP BendPak.
PROVIDING AUTOMOTIVE SERVICE SOLUTIONS

R Ranger.
PRODUCTS



For Parts or Service Contact:

BendPak Inc. / Ranger Products
1645 Lemonwood Dr.
Santa Paula, CA 93060

Tel: 1-805-933-9970
Toll Free: 1-800-253-2363
Fax: 1-800-933-9160

www.bendpak.com