

Portable Mid-Rise Scissor Lift

Installation and Operation Manual

Manual P/N 5900108 — Manual Revision F1 — September 2020

Models:

- MD-6XP



Designed and engineered by BendPak Inc. in Southern California, USA. Made in China.

 **DANGER**

Read the *entire contents* of this manual *before* using this product. Failure to follow the instructions and safety precautions in this manual can result in serious injury or death. Make sure all other operators also read this manual. Keep the manual near the product for future reference. ***By proceeding with setup and operation, you agree that you fully understand the contents of this manual and assume full responsibility for product use.***

Manual. MD-6XP Mid-Rise Scissor Lift, *Installation and Operation Manual*, Manual Part Number 5900108, Manual Revision F1, Released September 2020.

Copyright. Copyright © 2020 by BendPak Inc. All rights reserved. You may make copies of this document if you agree that: you will give full attribution to BendPak Inc., you will not make changes to the content, you do not gain any rights to this content, and you will not use the copies for commercial purposes.

Trademarks. BendPak and the BendPak logo are registered trademarks of BendPak Inc. All other company, product, and service names are used for identification only. All trademarks and registered trademarks mentioned in this manual are the property of their respective owners.

Limitations. Every effort has been made to ensure complete and accurate instructions are included in this manual. However, product updates, revisions, and/or changes may have occurred since this manual was published. BendPak reserves the right to change any information in this manual without incurring any obligation for equipment previously or subsequently sold. BendPak is not responsible for typographical errors in this manual. You can always find the latest version of the **manual for your product on the BendPak website**.

Warranty. The BendPak warranty is more than a commitment to you: it is also a commitment to the value of your new product. Contact your nearest BendPak dealer or visit www.bendpak.com/support/warranty for full warranty details. Go to bendpak.com/support/register-your-product/ and fill out the online form to register your product (be sure to click **Submit**).

Safety. Your product was designed and manufactured with safety in mind. However, your safety also depends on proper training and thoughtful operation. Do not install, operate, maintain, or repair the unit without reading and understanding this manual and the labels on the unit; **do not use your Lift unless you can do so safely!**

Owner Responsibility. In order to ensure operator safety and maintain your product properly, it is the responsibility of the product owner to read and follow these instructions:

- Follow all setup, operation, and maintenance instructions.
- Make sure product setup and use conforms to all applicable local, state, and federal codes, rules, and regulations, such as state and federal OSHA regulations and electrical codes.
- Read and follow all safety instructions. Keep them readily available for operators.
- Make sure all operators are properly trained, know how to safely operate the unit, and are properly supervised.
- Do not operate the product until you are certain all parts are in place and operating correctly.
- Carefully inspect the product on a regular basis and perform all maintenance as specified.
- Service and maintain the unit only with approved replacement parts.
- Keep all instructions permanently with the product and make sure all labels are clean and visible.
- **Only use the Lift if it can be used safely!**

Unit Information. Enter the Model Number, Serial Number, and the Date of Manufacture from the label on your unit. This information is required for part or warranty issues.

Model: _____

Serial: _____

Date of Manufacture: _____



BP BendPak		Santa Paula, CA USA www.bendpak.com
MODEL NUMBER		
DESCRIPTION		
LIFT CAPACITY	DATE OF MFG.	
VOLTAGE	SERIAL NUMBER	
<input type="checkbox"/> 110-240V, 50-60 Hz, 1 Ph		
<input type="checkbox"/> 208-240V, 50-60 Hz, 1 Ph		
<input type="checkbox"/> 380-415V, 50-60 Hz, 3 Ph		
<input type="checkbox"/> 208-440V, 50-60 Hz, 3 Ph		
		UPC
 DANGER! Disconnect Power Before Servicing		
WARRANTY VOID IF DATA PLATE IS REMOVED PN 5905951		

Table of Contents

Introduction	3	Operation	22
Shipping Information	4	Maintenance	27
Safety Considerations	4	Troubleshooting	27
Components	6	Wiring Diagrams	28
Specifications	7	Labels	29
Installation Checklist	8	Parts Diagrams	31
Installation	9	ALI Store	35

Introduction

This manual describes the MD-6XP, which is a mid-rise, frame-engaging, scissor Lift that is portable and comes with a small footprint designed for narrower bays and low-ceiling garages.

The MD-6XP can raise Vehicles up to 6,000 lbs (2,722 kg).

This manual is mandatory reading for all MD-6XP users, including anyone who sets up, operates, maintains, or repairs them.

⚠ DANGER Be very careful when setting up, operating, maintaining, or repairing this equipment; failure to do so could result in property damage, product damage, injury, or (in very rare cases) death. Make sure only authorized personnel operate this equipment. All repairs must be performed by an authorized technician. Do not make modifications to the unit; this voids the warranty and increases the chances of injury or property damage. Make sure to read and follow the instructions on the labels on the unit.

Keep this manual on or near the device so that anyone who uses or services it can read it.

If you are having issues, refer to the **Troubleshooting** section of this manual for assistance.

Technical support and service is available from your dealer, on the Web at bendpak.com/support, by email at support@bendpak.com, or by phone at **(800) 253-2363**, extension 196.

You may also contact BendPak for parts replacement information (please have the model and serial number of your unit available) at **(800) 253-2363**, extension 191.

Shipping Information

Your equipment was carefully checked before shipping. Nevertheless, you should thoroughly inspect the shipment **before** you sign to acknowledge that you received it.

When you sign the bill of lading, it tells the carrier that the items on the invoice were received in good condition. **Do not sign the bill of lading until after you have inspected the shipment.** If any of the items listed on the bill of lading are missing or damaged, do not accept the shipment until the carrier makes a notation on the bill of lading that lists the missing and/or damaged goods.

If you discover missing or damaged goods **after** you receive the shipment and have signed the bill of lading, notify the carrier at once and request the carrier to make an inspection. If the carrier will not make an inspection, prepare a signed statement to the effect that you have notified the carrier (on a specific date) and that the carrier has failed to comply with your request.

It is difficult to collect for loss or damage after you have given the carrier a signed bill of lading. If this happens to you, file a claim with the carrier promptly. Support your claim with copies of the bill of lading, freight bill, invoice, and photographs. Our willingness to assist in helping you process your claim does not make us responsible for collection of claims or replacement of lost or damaged materials.

Safety Considerations

Read this manual carefully before using your new product. Do not set up or operate the product until you are familiar with all operating instructions and warnings. Do not allow anyone else to operate the product until they are also familiar with all operating instructions and warnings.

General Safety Information

- The product is a mid-rise scissor Lift. Use it only for its intended purpose. Do not make any modifications to the product.
- The product should only be operated by authorized personnel.
- You **must** wear OSHA-approved (publication 3151) personal protective equipment at all times when installing, using, maintaining, or repairing the Lift: leather gloves, steel-toed work boots, eye protection, back belts, and hearing protection are **mandatory**.
- Keep loads centered and balanced on the Lift.
- **Never** exceed the rated capacity of the Lift.
- When the product is in use, keep all body parts away from it.
- Make sure all operators read and understand the *Installation and Operation Manual*. Keep the manual near the device at all times.
- Make a visual inspection of the product before using it. Check for damage or missing parts. Do not use the product if you find any issues. Instead, take it out of service, then contact your dealer, email support@bendpak.com, visit bendpak.com/support, or call **(800) 253-2363**.
- Make a thorough inspection at least once a year. Replace any damaged or severely worn parts, decals, or warning labels.

Symbols

Following are the symbols used in this manual:



DANGER

Calls attention to an immediate hazard that **will** result in injury or death.



WARNING

Calls attention to a hazard or unsafe practice that **could** result in injury or death.



CAUTION

Calls attention to a hazard or unsafe practice that could result in minor personal injury, product, or property damage.

NOTICE

Calls attention to a situation that, if not avoided, could result in product or property damage.



Tip

Calls attention to information that can help you use your product better.

Liability Information

BendPak Inc. assumes **no** liability for damages resulting from:

- Use of the product for purposes other than those described in this manual.
- Modifications to the equipment without prior, written permission from BendPak Inc.
- Injury or death caused by modifying, disabling, overriding, or removing safety features.
- Damage to the equipment from external influences.
- Incorrect operation of the equipment.

Components

MD-6XP components include:

- **Scissor Structure.** Holds the Lift together. Pivots in the middle. The two scissor pieces move together to raise the Lift, move apart to lower it.
- **Power Unit.** Provides Hydraulic Fluid to the Hydraulic Cylinders, which they use to raise the Scissor Structure. Connects to an external power source.
- **Platform.** Located on the top of the Scissor Structure. Holds the Arms and the Lift Pads.
- **Hydraulic Cylinders.** Move the Scissor Structure and Platform up to raise a Vehicle, move them down to lower a Vehicle.
- **Long Hydraulic Hose.** Connects to the Hydraulic Cylinder on the Lift closest to the Power Unit.
- **Short Hydraulic Hose.** Connects the two Hydraulic Cylinders on the Lift.
- **Safety Locks.** Hold the Platform in place, once they are engaged. The MD-6XP has three Safety Lock positions, which lets you select the right Vehicle height for your needs.
- **Latch.** Located at the Base of the Lift, used for moving the Lift around.
- **Lift Arm.** Attaches to the inside channels of the Platform, used for holding the Lift Pads.
- **Lift Pads.** Black, rubber Pads that make contact with the Lifting Points on the underside of the Vehicle being raised; do **not** raise a Vehicle on the Platform. The Lift comes with four Short Pads and four Tall Pads/Adapters/Bases. Using the Lift Pads is **required**.
- **Portable Stand.** Holds the Power Unit, has two mounting holes to attach the Power Unit.
- **Tow Cart.** Used for moving the Lift around your work space.
- **Tow Pin.** Attached to the Tow Cart, hooks to the Lift so you can move it.

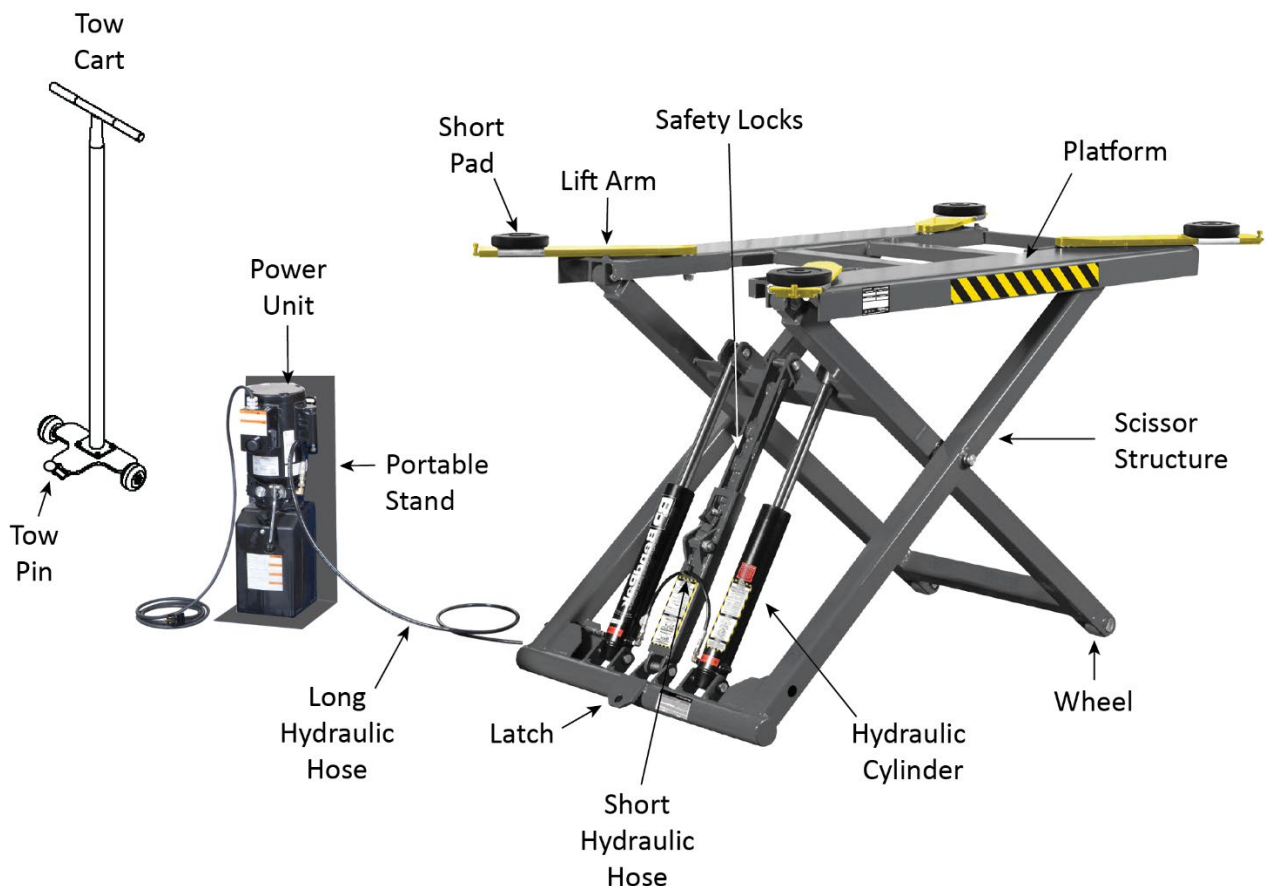

Specifications

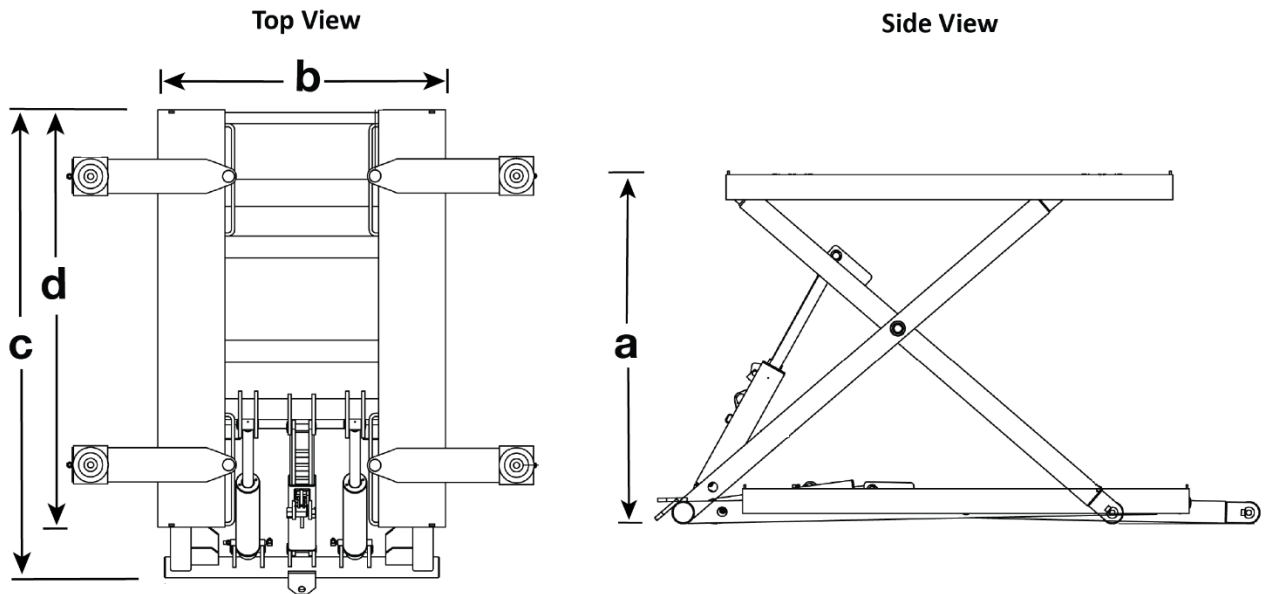

Model	MD-6XP
Lifting capacity	6,000 lbs. / 2,722 kg
a Lifting Height (no Pads)*	47" (3.9 feet) / 1,190 mm
b Overall Width	41.5" (3.6 feet) / 1,054 mm
c Overall Length	76" (6.4 feet) / 1,930 mm
d Frame Length	60" (5 feet) / 1,524 mm
Lowered Height	4.75" / 121 mm
Top Locking Position (no Pads)**	42" (3.5 feet) / 1,067 mm
Middle Locking Position (no Pads)**	33.25" (2.8 feet) / 844 mm
Bottom Locking Position (no Pads)**	22" (1.8 feet) / 562 mm
Raising/Lowering Time***	45 seconds
Motor****	115/220 VAC, 50/60 Hz, 1 Ph

* Distance is from ground to top of Platform; does **not** include height of Arms or Pads.

** For height comparison only; **do not raise a Vehicle without Lift Pads.**

*** Lowering is much slower with no Vehicle on the Lift.

**** Must specify at time of ordering.

Specifications subject to change without notice.

Installation Checklist

Following are the steps needed to install an MD-6XP Lift. Perform them in the order shown.

- 1. Review the installation Safety Rules.
- 2. Make sure you have the necessary Tools.
- 3. Select the Installation Site.
- 4. Planning for Electrical Work.
- 5. Check clearances.
- 6. Unloading and unpacking.
- 7. Assemble the Portable Stand.
- 8. Attach the Power Unit to the Portable Stand.
- 9. Set up the Tow Cart.
- 10. About Hydraulic Fluid Contamination.
- 11. About Thread Sealants.
- 12. Connect the Hydraulic Hoses.
- 13. Install the Lift Arms.
- 14. Connect the Power Unit.
- 15. Install a Thermal Disconnect Switch (Electrician **required**).
- 16. Fill the Hydraulic Fluid Reservoir.
- 17. Test the Lift.
- 18. Review the Final Checklist.

Installation

This section describes how to install an MD-6XP. Perform the steps in the order listed.

 **WARNING** *Use only the factory-supplied parts that came with your Lift.* If you use parts from a different source, you void your warranty and compromise the safety of everyone who installs or uses the Lift. If you are missing parts, visit bendpak.com/support or call **(800) 253-2363**, extension 191.

Safety Rules

When installing the Lift, your safety depends on proper training and thoughtful operation.

 **WARNING** Do not install this equipment unless you have automotive Lift installation training. Always use proper tools, such as a Forklift or Shop Crane, to move heavy components. Do not install this equipment without reading and understanding this manual and the safety labels on the unit.

BendPak recommends referring to the ANSI/ALI ALIS Standard (R2015) *Safety Requirements for Installation and Service* for more information about safely installing, using, and servicing your Lift.

Only fully trained personnel should be involved in installing this equipment. ***Pay attention at all times.*** Use appropriate tools and equipment. Stay clear of moving parts.

 **WARNING** You ***must*** wear OSHA-approved (publication 3151) personal protective equipment at all times when installing, using, maintaining, or repairing the Lift: leather gloves, steel-toed work boots, eye protection, back belts, and hearing protection are ***mandatory.***

Tools

You may need some or all of the following tools:

- Hammer, mallet, crowbar, or pry bar
- Open-end wrench set
- Socket and ratchet set
- Medium crescent wrench
- Medium flat screwdriver
- Tape measure
- Fork Lift or Shop Crane

Select a Site

The MD-6XP is portable, so you may be moving it and using it at a variety of locations. Keep the following in mind when selecting a location for your Lift:

- **Clearance.** You must have adequate space on all sides, plus enough space above for the Vehicles you will be raising. See **Clearance Around the Lift** for more information.
- **Check for overhead obstructions.** Check for overhead obstructions such as building supports, heaters, electrical lines, low ceilings, hanging lights, and so on. ***You do not want the Vehicles on the Lift hitting obstructions.***
- **Operator.** The operator ***must*** have a full, unobstructed view of the Lift when raising and lowering Vehicles.
- **Level Floor.** Only install the Lift on a dry, flat, and stable floor; do not install the Lift on dirt or an uneven surface.
- **Concrete specifications.** Do not install the Lift on or within 6 in / 152 mm of expansion seams or cracked or defective concrete. Make sure the concrete is at least 4.25 inches thick, 3,000 psi, and cured for at least 28 days (if newly poured).
- **Power.** You will need a 115 VAC or 220 VAC power source available near the Power Unit.
- **Operating temperature.** The Lift is designed to be used between temperatures of 41° to 104°F (5° to 40°C).
- **Outdoor installation.** The Lift ***cannot*** be installed outside. It is designed for indoor use only. If you use it outside, use it outside temporarily; make sure to keep it completely moisture free while it is outside.

⚠ DANGER Keep the Power Unit away from damp environments; the motor must ***not*** get wet.

- **Second floor installs.** Do not install the Lift on a second floor or elevated floor without first consulting the building architect and getting their permission.
- **Dress properly.** Always wear protective gear when installing the Lift. Leather gloves, steel-toed work boots, eye protection, back belts, and hearing protection ***are mandatory***. Do ***not*** wear loose clothing or jewelry; contain long hair; keep hair, clothing, and gloves away from moving parts.

⚠ WARNING You ***must*** wear OSHA-approved (publication 3151) Personal Protective Equipment ***at all times*** when using the Lift.

Planning for Electrical Work (220 VAC only)

If you received a Power Unit configured for 220 VAC operation (must have been specified at the time of ordering), you will need to have a licensed, certified Electrician at some point in the installation.

⚠ DANGER All wiring ***must*** be performed by a licensed, certified Electrician.

A Power Unit configured for 220 VAC operation is shipped with a pigtail for wiring to the power source. Have your Electrician remove the pigtail and wire from inside the Electrical Box on the Power Unit to an appropriate Power Cord and Plug.

Note: The Power Cord and Plug are ***not*** supplied with the Lift.

Clearance Around the Lift

For safety purposes, a certain amount of clear space around the Lift is **required**.

Extra distance is required on both ends so that you can drive Vehicles onto and off of the Lift in either direction.

You also need to make sure to leave enough space **above** the Vehicles you will be raising. Be sure to check for low-hanging obstructions such as hanging lights, beams, and so on.

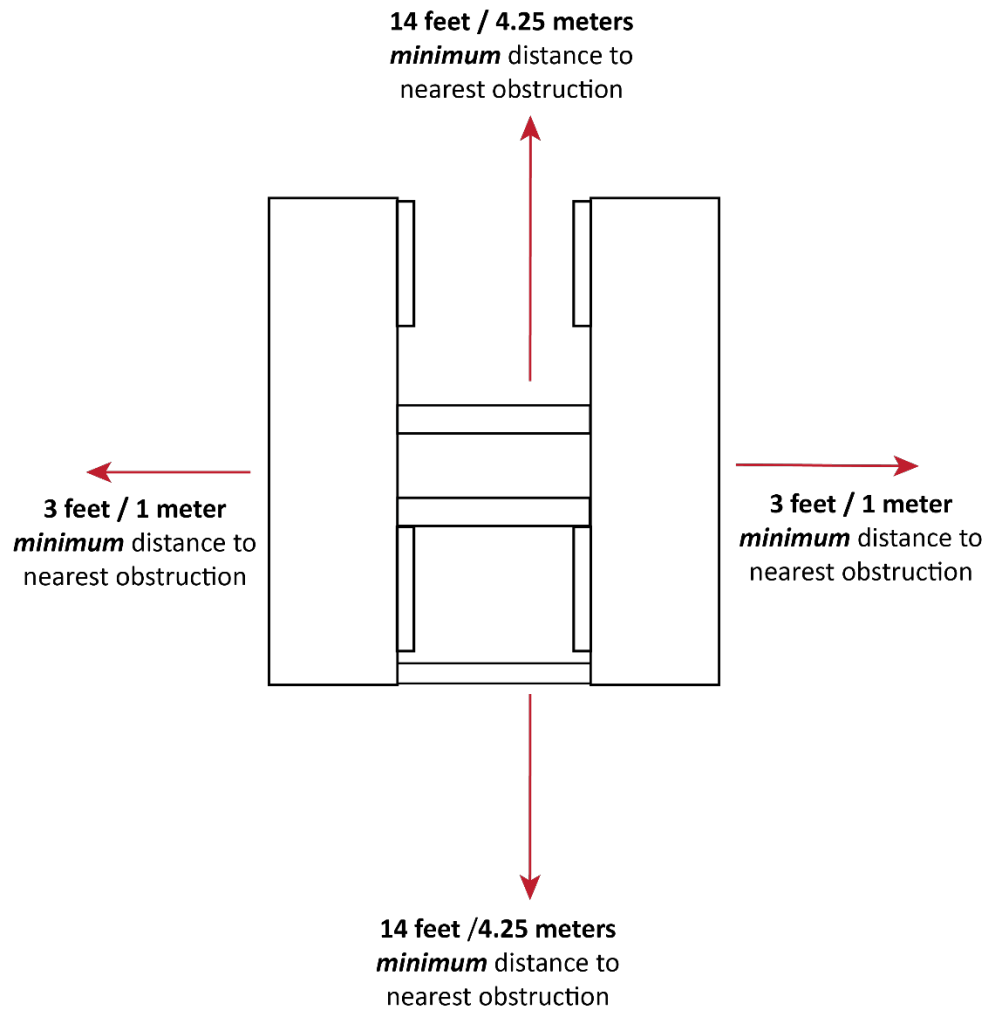

Unloading and Unpacking

Try to have the components of the Lift unloaded near the installation location.

Once the components are unloaded, it is your responsibility to move them around. As the Lift includes a number of heavy pieces, the closer you unload it to the installation location, the better off you are.

⚠ CAUTION The Frame is heavy; if handled incorrectly, it can damage materials like tile, sandstone, and brick. Try to handle the Lift components twice: once when delivered and once when moved to the installation location. Use care when moving the Frame.

Assemble the Portable Stand

The Portable Stand allows you to easily move the Power Unit to a location near the Lift.
Assemble the Portable Stand as shown below.

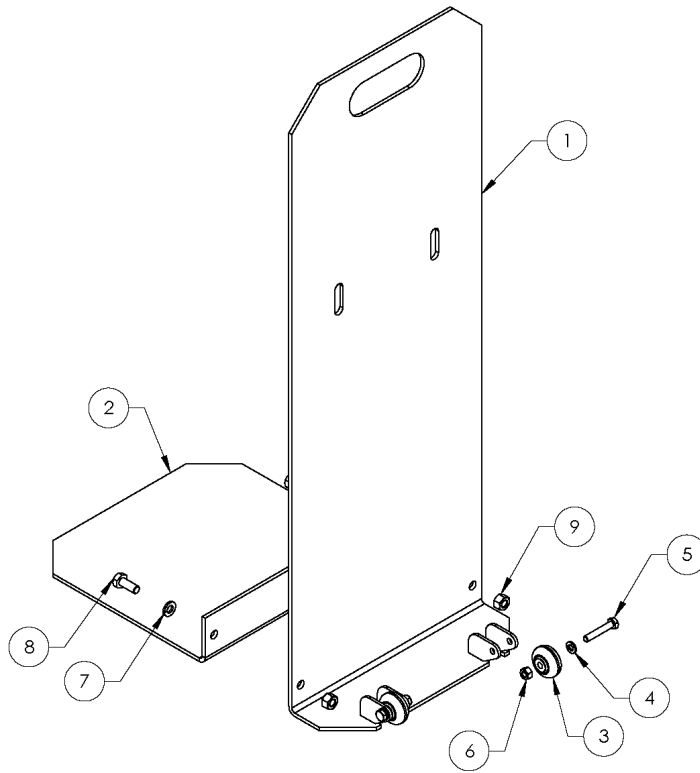

Item No.	Part Number	Description	Qty
1	5601407	Low Rise Power Unit Stand	1
2	5737141	Low Rise Power Unit Extension Plate	1
3	5716192	Polyurethane Wheel	2
4	5545026	Washer M6 x Ø12 SL	2
5	5530027	HHB M6 x 1.0 x 35	2
6	5535357	Nut M6 x 1.0 NL	2
7	5545202	Washer M8 x Ø 15 SL	2
8	5530304	HHB M8 x 1.25 x 20	2
9	5535001	Nut M8 x 1.25 NL	2

Attach the Power Unit to the Portable Stand

Attach the Power Unit to the Portable Stand using the included M8 x 25 mm Bolts, Washers, and Nuts.



Tip The Power Unit is heavy and awkward. We recommend having one person hold the Power Unit while a second person bolts it onto the Stand.

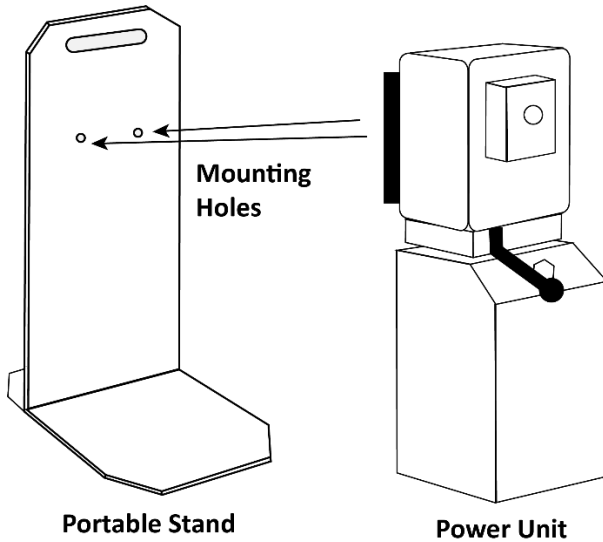

Set up the Tow Cart

The Tow Cart lets you move the Lift around your work space. Keep the Tow Cart in an accessible area for future use.

The following drawing shows how to set up the Tow Cart.

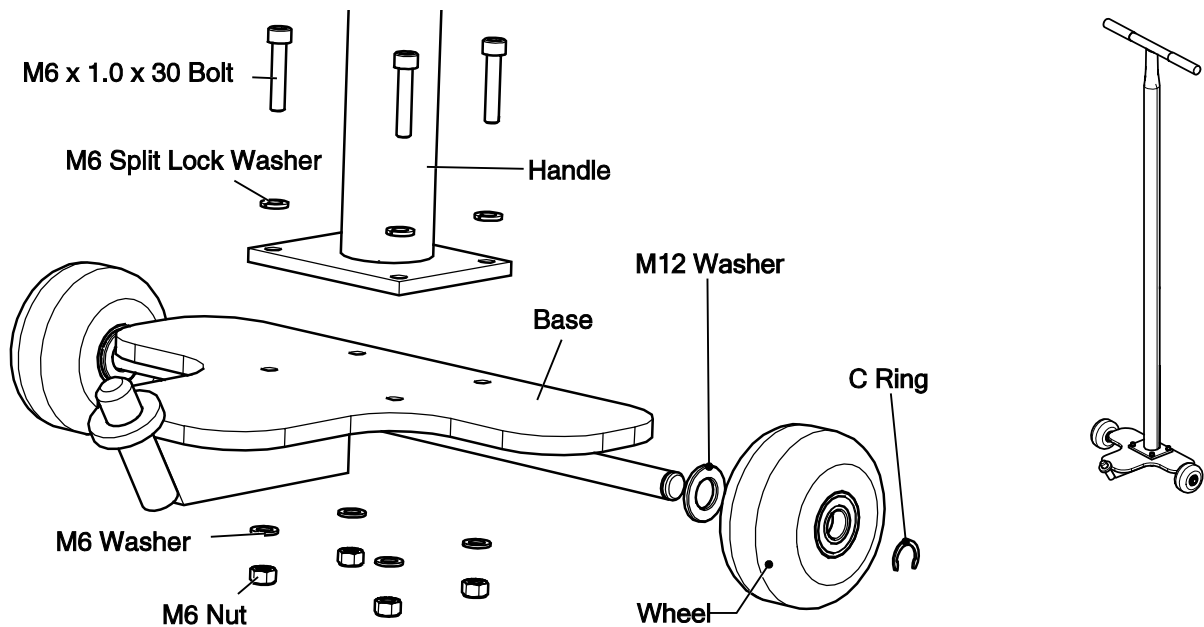



IMPORTANT! PLEASE READ NOW



Hydraulic Fluid Contamination

Hydraulic Fluid Contamination poses a **serious** issue for your Lift; contaminants such as water, dirt, or other debris can get into the Hydraulic Hoses and Fittings on the Lift, making your new Lift inoperable.

Your Lift is shipped with clean components; however, Bendpak strongly recommends that you take secondary precaution and clean all Hydraulic Hoses and Fittings prior to making connections. It is better and less costly to take these extra steps now so that you do not need to take your Lift out of service later to fix issues that could have been prevented at the time of installation.

There are several ways to clean Hydraulic Hoses and Fittings:

- **Compressed Air.** Use an air compressor to blow out contaminants from each Hydraulic Hose and Fitting prior to installation. Clean, dry air is preferred. Wear eye protection (safety glasses, goggled, or face shield) when using compressed air for cleaning. Never point an air hose nozzle at any part of your body or any other person.
- **Fluid Flushing.** As long as the Hydraulic Fluid is clean and compatible with the system fluid, you can flush the Hoses and Fittings to create turbulent flow and remove particulates. Always ensure that the fluid itself is contaminant-free.

Some additional steps that will keep the Hydraulic Fluid clean:

- **Remove old thread seal tape.** Some ports on the Hydraulic Cylinders are shipped with temporary plugs secured with thread seal tape, so make sure to thoroughly remove any leftover thread seal tape that may inadvertently enter the Hydraulic System.
- **Use a liquid thread sealant only.** Teflon paste-type thread sealant or Loctite™ 5452 thread sealant is recommended for all NPT Fittings. Do not over tighten NPT Fittings or they may crack. Never use thread seal tape on JIC Fittings or ORB O-Ring Fittings.
- **Always use clean equipment.** If you use a dirty bucket or funnel to transfer the Hydraulic Fluid into the Hydraulic Fluid Reservoir, the more likely it is that contaminants will be introduced to the Fluid. If you use cleaning rags, use a lint-free rag.
- **Proper storage.** Keep the Hydraulic Fluid sealed in its container until ready for use; store the fluid in a dry, clean, and cool area.
- **Cover the Fittings.** During installation or when performing maintenance on the Lift, do not leave the ends of the Fittings exposed; the same applies for the Hydraulic Hoses. As a general rule, keep the Hydraulic Hoses and Fittings capped and kept in a clean area until ready for use.
- **Filter the new Hydraulic Fluid.** Just because it is new does not necessarily mean it is *clean*. Use an offline filtration cart or kidney loop system to make sure the Hydraulic Fluid is clean before being transferred into the Hydraulic Fluid Reservoir (even using a heavy duty nylon mesh screen is better than trusting what is left at the bottom of the barrel).
- **Avoid mixing different types of Hydraulic Fluid.** If Hydraulic Fluid needs to be replaced, make sure to flush the Hydraulic System of the old Hydraulic Fluid before you add the replacement fluid; do not mix the two together.

About Thread Sealants

The efficiency of your Lift's Hydraulic system relies on secure connections, which help prevent leaks and keep contaminants out. We recommend using a Liquid Thread Sealant (like Loctite™ 5452 or similar PTFE Thread Sealant) to seal the Hydraulic components on your Lift.

Thread Sealant can be used with most Hydraulic Fittings, although you probably only need to use it with NPT connectors.

To apply Thread Sealant:

1. Make sure the Fittings and connectors you are going to use are clean and dry.

If you are adding Thread Sealant to a Fitting or connector that has already been used with a different sealant, use a wire brush to thoroughly remove the old sealant before adding more.

2. Apply a small amount of Thread Sealant to the first four threads of the Fitting.

 **WARNING** Make sure to wear the proper protective equipment when handling Thread Sealant.

You only need a small amount because the sealant spreads to the other threads as it is tightened into place.

If you put too much, the excess liquid will be pushed out when the Fitting is tightened; use a rag to wipe the excess.

3. Tighten the Fitting into the connector; do **not** over tighten the Fitting.
4. Allow the manufacturer-recommended curing time before pressurizing the system.

Connect the Hydraulic Hoses

Hydraulic Hoses provide Hydraulic Fluid to the Hydraulic Cylinders, where it is used to raise the Platform.

The Power Unit can be placed on either side of the Frame, as long as the operator has an unobstructed view of the Lift **at all times**.

The following drawing shows how to route the Hydraulic Hoses on the Lift.

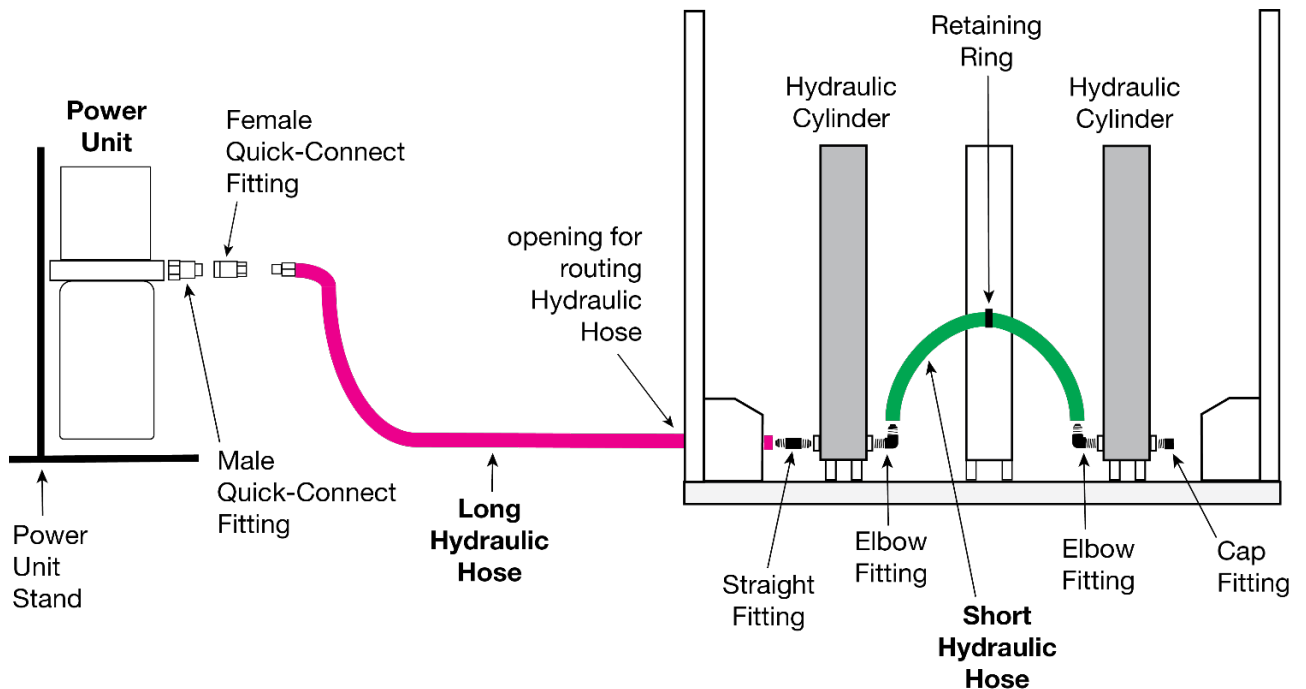

Drawing shows Power Unit on the left side of the Frame. Drawing not to scale. Some components not shown, other components exaggerated for clarity.

To connect the Hydraulic Hoses:

1. Locate the Long Hydraulic Hose, two Quick-Connect Fittings, and a Straight Fitting.
2. Clean the Hydraulic components using the information in [Hydraulic Fluid Contamination](#).
3. The Short Hydraulic Hose is shipped from the factory already connected between the Hydraulic Cylinders.

If it is not, remove the Shipping Plugs from the Hydraulic Hose Ports near the bottom of each Hydraulic Cylinder on the Lift, attach Hydraulic Elbow Fittings (04 JIC – 04 NPT) to the inside Hydraulic ports, and then connect the Short Hydraulic Hose to the Elbow Fittings you just attached, making sure to route the Hose through the Retaining Ring near the top of the Hydraulic Cylinders.

Make sure to keep the Hydraulic Cylinder Ports and Fittings contaminant-free.

4. Attach a Hydraulic Straight Fitting (NPL 04 JIC – 04 NPT) to the outside Hydraulic Port of the Hydraulic Cylinder closest to where the Power Unit will be.
5. Route the Long Hydraulic Hose through the opening in the Frame, and then connect it to the Straight Fitting.
6. Connect the Female Quick-Connect Fitting to the other end of the Hydraulic Hose.

-
7. On the Power Unit, remove the Shipping Plug from the Hydraulic Out Port you want to use; it does not matter which one you use.

The following drawing shows the possible port configurations, depending on your Power Unit.

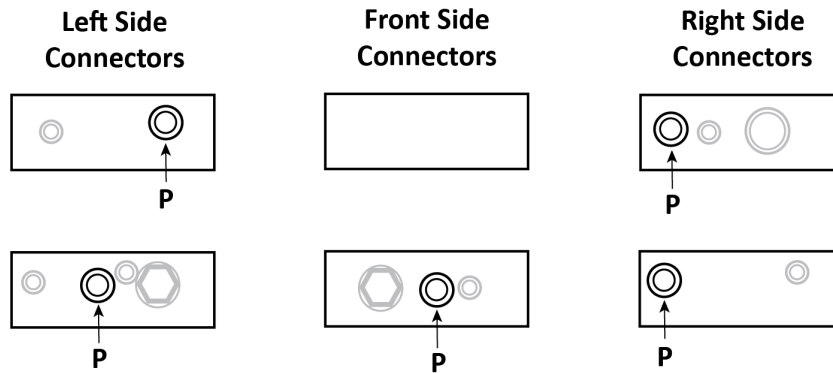

Hydraulic Out Ports are usually labeled P on the Power Unit. Not all components of the Power Unit are shown. Not drawn to scale.

8. Attach the ORB end of the Male Quick-Connect Fitting to the Power Unit, then connect the other end of the Male Quick-Connect Fitting to the Female Quick-Connect Fitting.

Once all Hoses and Fittings have been attached, securely tighten all connections.

Install the Lift Arms

The Lift Arms are used with the Lift Pad accessories so that you can raise a Vehicle by the manufacturer's recommended Lifting Points.

The following drawing shows the Lift Arm.

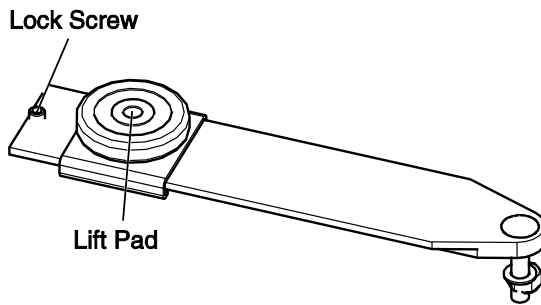

To install the Lifting Arms:

1. Remove the Washer and Nut from the Lift Arm Pin.
2. Slide the Pin through the Channel and secure the Pin in place with the same Washer and Nut.

Do **not** over-tighten the Nut; keep it loose enough so that the Arm can move and pivot within the Channel.

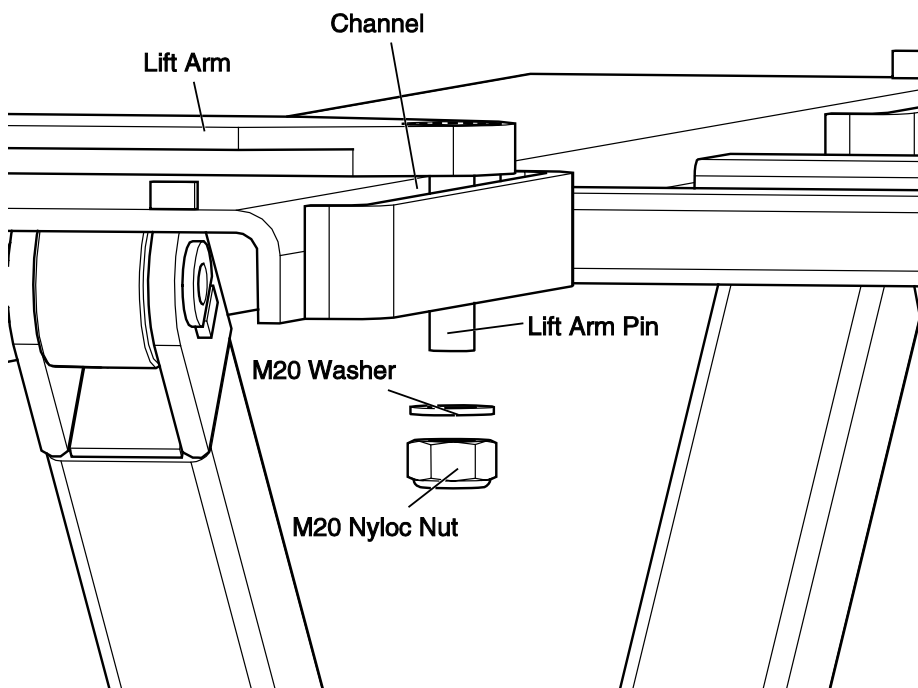

3. Repeat Steps 1 and 2 for the remaining Lift Arms.

Each Lift Arm can be fitted with either a Short Pad or a Tall Pad/Adapter/Base combination based on the Vehicles you will be raising.

To switch them, remove the Lock Screw on the end of the Lift Arm, remove the current Pad, slide on the desired Pad, and then replace the Lock Screw.

Connect the Power Unit

The standard Power Unit for your Lift comes fully assembled from the factory, configured for 115 VAC operation.

If you have a 220 VAC Power Unit, it will come with a pigtail for wiring to a power source. Have your Electrician remove the pigtail and wire from inside the Electrical Box on the Power Unit to an appropriate Power Cord and Plug.

Important electrical information:

- Improper electrical installation can damage the Power Unit motor; this damage is not covered under warranty.
- Use a separate circuit breaker for each Power Unit.
- The circuit must be grounded and protected with a time-delay fuse or circuit breaker. For a 115 VAC, 1 phase circuit, use a 20 amp or greater fuse. For a 230 VAC, 1 phase circuit, use a 25 amp or greater breaker.

⚠ DANGER All wiring **must** be performed by a licensed, certified Electrician.

⚠ CAUTION The Power Unit's Motor is **not** thermally protected.

The following drawing shows the Power Unit for your Lift (220 VAC option only).

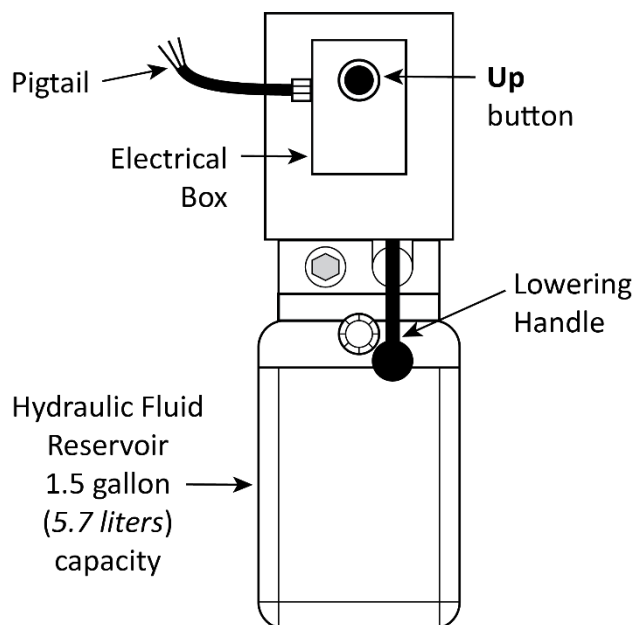

To connect to a power source:

4. Find the Power Cord on the Power Unit, and then make sure the Power Cord has an appropriate plug on the end.

Important: If you have a 220 VAC Power Unit, have your Electrician put a 220 VAC Plug appropriate for your location. **Remember, all wiring must be performed by a licensed, certified Electrician for this process.**

5. Plug the Power Cord to an appropriate power outlet.
6. Begin using the Lift.

Install a Thermal Disconnect Switch

 **WARNING** The motor on the Power Unit supplied with your Lift has no thermal overload protection.

Have the Electrician connect a motor Thermal Disconnect Switch or overload device that will make sure the equipment shuts down in the event of an overload or an overheated motor.

 **DANGER** Installing a Thermal Disconnect Switch **must** be performed by a licensed, certified Electrician. Do not perform **any** maintenance or installation on the Lift without first making sure that main electrical power has been disconnected from the Lift and **cannot** be re-energized until all procedures are complete.

High running amps that exceed the motor's full load amps (FLA) rating may result in permanent damage to the motor.

BendPak strongly recommends you **not** exceed the rated duty cycle of the motor.

Fill the Hydraulic Fluid Reservoir

The Hydraulic Fluid Reservoir on the Power Unit must be filled with Hydraulic Fluid or automatic transmission fluid before you begin normal operation.

The Hydraulic Fluid Reservoir holds approximately **1.5 gallons / 5.7 liters**.

The Power Unit will **not** work correctly until the reservoir is filled with approved Hydraulic Fluid.

Approved Hydraulic Fluids are any general purpose ISO-32, ISO-46, or ISO-68 hydraulic oil or approved automatic transmission fluids such as Dexron III, Dexron VI, Mercon V, Mercon LV, Shell Tellus S4 / S3 / S2, or any synthetic multi-vehicle automatic transmission fluid.

 **WARNING** Do not run the Power Unit without Hydraulic Fluid; you will damage it.

Test the Lift

Before putting your Lift into normal operation, we recommend raising and lowering it a few times. This will help you get a feel for how to operate the controls and help get any residual air out of the Hydraulic System (sometimes called “bleeding” the system).



Tip

Residual air in the Hydraulic System can cause the Lift to shake, move erratically, or squeak; this is normal when you first start using the Lift. It will soon stop doing this, as the Hydraulic System is self-bleeding.

To test your Lift:

1. Check the area around and above the Lift for obstructions; move them away if you find any.
2. Make sure the Lift is fully lowered.
3. On the Power Unit, press and hold the **Up** button.
4. When the Lift moves past the first Safety Lock, release **Up**.
5. *Press and hold* the Lowering Handle.
6. When the Lift gets to the ground, release the Lowering Handle.
Wait for one minute.
7. Repeat the process, this time raising the Lift to the top Safety Lock and then lowering it back down to the ground.
8. If the Lift is working without shaking, moving erratically, or squeaking, there is no need to repeat the procedure.

If the Lift is shaking, moving erratically, or squeaking, repeat the procedure one more time.

If you continue to have issues, refer to **Troubleshooting** for assistance.

Final Checklist Before Operation

Make sure these things have been done before using your Lift:

- Review the **Installation Checklist** to make sure all steps have been performed.
- Check the Hydraulic Fluid reservoir; it must be full of approved Hydraulic Fluid or automatic transmission fluid. **You can harm the motor by running it without enough fluid.**
- Check the Hydraulic System for leaks.
- Make sure that all Safety Locks are cleared and free.
- Leave the Manual with the Owner/Operator so that it is available for anyone who needs to read it.

Operation

This section describes how to operate your Automotive Lift.

⚠ DANGER When you even hear the words “Automotive Lift,” your brain should automatically remember that lifting a Vehicle is a serious endeavor with life-threatening risks. Focus on what you are doing. Automotive Lifts are dangerous tools when used by inexperienced or impaired operators. ***Do not assume you are going to be safe this time because nothing happened last time.***

Safety Considerations

⚠ WARNING Your safety is dependent on reading, understanding, and implementing these Safety Rules. ***Do not skip over them—read them carefully and follow them; your life could literally depend on it!***

Do the following **before** you raise a Vehicle on your Lift, do the following each time:

- **Check the Lift.** Walk all the way around the Lift, checking for any missing, heavily worn, or damaged parts. Do not operate the Lift if you find any issues; instead, take it out of service, then contact your dealer, email support@bendpak.com, or call **(800) 253-2363**.
- **Check the area.** Keep the area around and under the Lift clean and free of obstructions; anything that could cause a problem. Do not forget to check **above** the Lift. If you find an obstruction, move it out of the way.
- **Check the operators.** Make sure everyone who is going to operate the Lift has been trained in its use, has read the labels on the unit, and has read the manual. Only the operator at the Controls should be within 30 feet of the Lift while it is moving. Do not allow children to operate the Lift. Do not allow anyone under the influence of drugs, alcohol, or medication to operate the Lift. Do not allow any unauthorized personnel to operate the Lift.
- **Check for safety.** Make sure everyone who is going to be walking near the Lift is aware of its presence and takes appropriate safety measures. Only put Vehicles on the Platform. When raising a Vehicle, do not leave it until it is **engaged** on a Safety Lock. When lowering the Lift, do not leave it until it is on the ground.
- **Check the Vehicle.** Never exceed the Lift’s weight rating. Do not allow people inside a Vehicle you are going to raise. Make sure the Vehicle is not overbalanced on either end or either side.

About Safety Locks

Your Lift comes with three Safety Lock positions; they serve two important functions:

- **Safety.** Safety Locks hold the Platform in place. Once the Lift is engaged on the desired Safety Lock, the weight of the Vehicle holds the Platform in place. If the power goes out, the Safety Lock holds the Platform, and anything on it, in place.

⚠ WARNING Always leave your Lift engaged on a Safety Lock or fully lowered. Although rare, it is possible for Hydraulic Fluid in the Hydraulic Cylinders to leak, causing the Platform to slowly come down if it is *not* engaged on a Safety Lock.

- **Adjustable height.** Having multiple Safety Locks means you can raise the Vehicle to just the right height for the work you are performing.

To put your Lift on a Safety Lock:

1. Press the **Up** button on the Power Unit to raise the Platform.

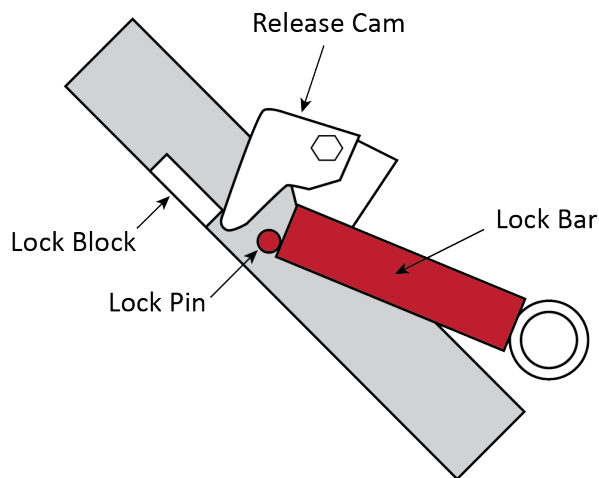

The Release Cam has not passed over the Lock Block; the Lift would **not** go on a Safety Lock at this point.

2. To use that Safety Lock, keep pressing **Up** for another half a second, then release **Up**.
3. Press and hold the Lowering Handle for a few seconds; the Release Cam moves into a locked position on the Lock Block it just passed.

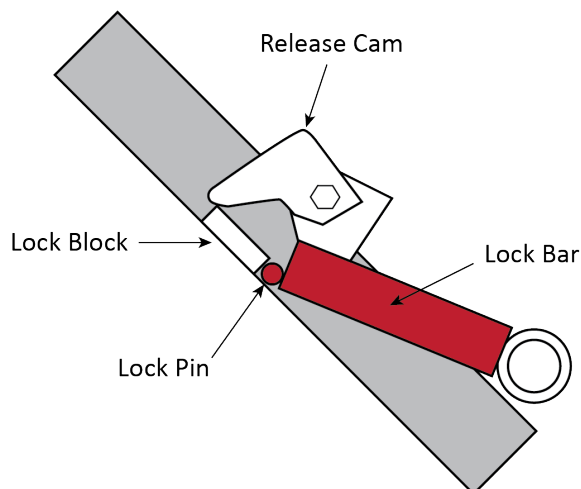

If you miss the desired Safety Lock, there's no problem; just try it again until you get it right.

Raising a Vehicle

This section describes how to raise a Vehicle on the Lift.

To raise a Vehicle:

1. Check the items listed in **Safety Considerations**.

If you find any issues, resolve them **before** raising the Vehicle; **only use the Lift if it can be used safely**.

2. Make sure the Lift is fully lowered and the Lift Arms are out of the way.

3. Drive the Vehicle over the Lift and then stop.

4. Put the Vehicle in park, put on the parking brake, and turn off the Vehicle.

If the Vehicle is a manual transmission, put it into first gear before turning it off; you do not want the Vehicle moving while it is raised.

5. Walk around the Vehicle and make sure there are no obstructions or any other issues that will interfere with the raising the Lift.

6. Position the Lifting Arms on the manufacturer's recommended Lifting Points of the Vehicle you are raising.

If you are unsure where the Lifting Points are, consult *Vehicle Lifting Points for Frame Engaging Lifts*, which is available on the ALI website (www.autolift.org/ali-store), or provided by the manufacturer of the Vehicle.

7. Put the Lift Pads under the Vehicle so that they are **directly under** the Lifting Points for the Vehicle you are raising.

If necessary, use the included Lift Pad Extensions for extra height.

8. On the front of the Power Unit, press and hold the **Up** Button to raise the Lift until **just before** the Lifting Arms make contact with the Lifting Points.

9. Check to make sure the Lifting Arms will make solid contact with the Lifting Points when raised further.

Adjust them if necessary.

10. Raise the Lift until the tires of the Vehicle are a few inches off the ground.

If the Lift becomes unstable or the Vehicle starts moving, release the **Up** Button immediately.

11. Check to make sure the Lift Arms are making solid contact with the Lifting Points.

If any of the Lift Pads are not making solid contact with the Lifting Points, lower the Lift and adjust the Lift Pads so that they make better contact.

12. Rock the Vehicle to make sure the Vehicle is stable and balanced.

If the Vehicle is **not** stable and balanced, lower the Lift back to the ground and start over.

If the Vehicle **is** stable and balanced, it is safe to raise further.

⚠ DANGER Do **not** raise the Lift further until you are certain the Vehicle on the Lift is both stable and balanced. If the Vehicle is **not** stable and balanced, it could fall, which could damage the Vehicle, damage the Lift, or injure or kill anyone under the Vehicle.

13. On the Power Unit, press and hold the **Up** button.

14. When the Lift just passes the desired height, release the **Up** button.

-
15. **Press and hold** the Lowering Handle briefly to move the Lift back down, which engages it on the most recently passed Safety Lock.

If you miss the desired Safety Lock, press and hold **Up** again and go for somewhat further past the desired Safety Lock. Release **Up**, then hold the Lowering Handle again to lower the Platform onto the desired Safety Lock.

Lowering a Vehicle

This section describes how to lower a Vehicle that is raised on the Lift.

To lower a Vehicle:

1. Check the items listed in **Safety Considerations**.

If you find any issues, resolve them **before** starting to lower the Vehicle.

2. On the Power Unit, press and hold the **Up** Button for a few seconds.

This moves the Lift off the Safety Lock on which it was engaged.

The following drawing shows the Release Cam disengaged from the Lock Block.

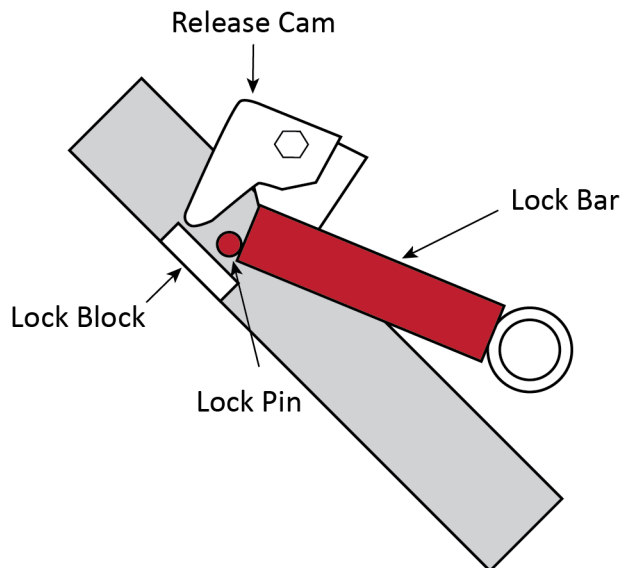

3. **Press and hold** the Lowering Handle on the Power Unit.
4. When the Lift is fully lowered, release the Lowering Handle.
5. Push the Lift Arms in towards the Frame.
This is so they are not in the way when the Vehicle is moved.
6. Carefully drive the Vehicle off the Lift.

Move the Lift

⚠ DANGER Do **not** move the Lift or perform any maintenance without first confirming that electrical power has been disconnected and cannot be re-energized.

The following drawing shows the components used to move the Lift.

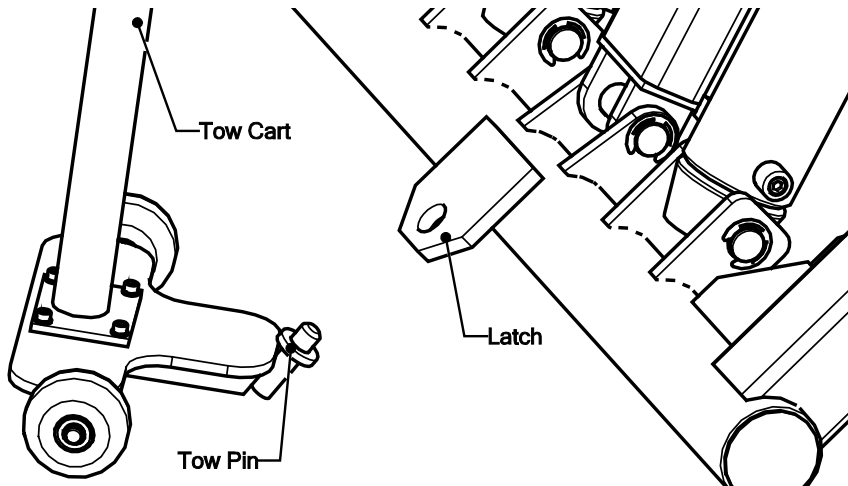

To move the Lift:

1. Make sure the Lift is fully lowered, then disconnect the Quick-Connect Fitting from the Long Hydraulic Hose.

⚠ WARNING Do **not** attempt to connect or disconnect the Hydraulic Hoses while equipment is loaded or while the Hydraulic System is under pressure.

2. Hook the Tow Pin into the Latch near the bottom the Frame.
3. Using a downward force, push the Tow Cart to raise the Lift onto its rear wheels, and then carefully move the Lift to the desired location.

Lubricate the Lift

The following drawing shows the lubrication points on the Lift.

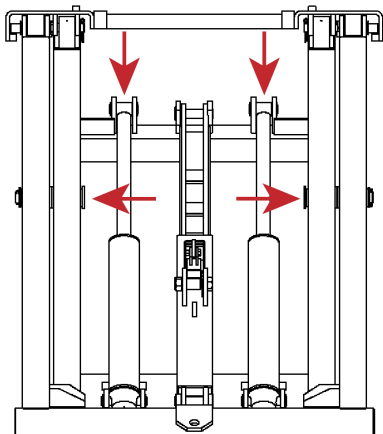

Maintenance

⚠ DANGER Before performing maintenance on your Lift, make sure it is disconnected from power. The Lift uses electrical energy; if your organization has Lockout/Tagout policies, make sure to implement them before performing any maintenance. If you come into contact with high voltage/current, you could be injured or killed.

To maintain your Lift:

- **Daily:** Keep the Lift clean. Wipe up any oil spills, clean any dirt.
- **Daily:** Make a visual inspection of all moving parts and check for damage or excessive wear. If you find any damaged or worn parts, take the Lift out of service until they are replaced.
- **Daily:** Make sure the Safety Locks are in good operating condition. If you find that the Safety Locks are damaged or excessively worn, take the Lift out of service until they are replaced. **Do not use your Lift if the Safety Locks are damaged or excessively worn.**
- **Weekly:** Check all controls to make sure they are functioning normally.
- **Weekly:** Check all labels on the unit. Replace them if they are illegible or missing.
- **Monthly:** Lubricate the grease fittings. We recommend using white lithium grease or similar.
- **Monthly:** Check the Power Unit's Hydraulic Fluid levels. Refill if low.

⚠ WARNING: Do not operate your Lift if you find issues; instead, take it out of service, then contact your dealer, email support@bendpak.com, visit bendpak.com/support, or call **(800) 253-2363**, extension 196.

Troubleshooting

This section describes how to troubleshoot your Lift.

Note: If your Lift is not functioning correctly, you must take it out of service until it is fixed. All repair work must be done by qualified personnel.

⚠ WARNING The Lift uses electrical energy; if your organization has Lockout/Tagout policies, make sure to implement them before performing any Troubleshooting.

Issue	Action to Take
Platform moves erratically or squeaks when in use.	Move the Platform up and down a few times, with a break between each; there could be residual air in the Hydraulic System.
Platform does not go up or down.	Make sure the Power Unit is connected to an appropriate power source. Make sure none of the Hydraulic Hoses are pinched or leaking. Make sure there is sufficient Hydraulic Fluid in the reservoir on the Power Unit.
Hydraulic Fluid is old or dirty.	Replace the dirty fluid with clean, approved Hydraulic Fluids, such as Dexron III, Dexron VI, Mercon V, Mercon LV, Shell Tellus S4 / S3 / S2, or comparable.

Lift make odd noises when in use.	Lubricate hinge points using white lithium grease.
Lift is slowly lowering on its own.	Make sure the Lift is engaged on a Safety Lock (if not, Hydraulic Fluid could be getting pushed back into the tank on the Power Unit, lowering the Lift). <i>Only leave the Lift either fully lowered or engaged on a Safety Lock.</i>

If you continue to have problems with your Lift, contact your dealer, visit bendpak.com/support, email support@bendpak.com, or call **(800) 253-2363**, extension 196.

Wiring Diagrams

5585435

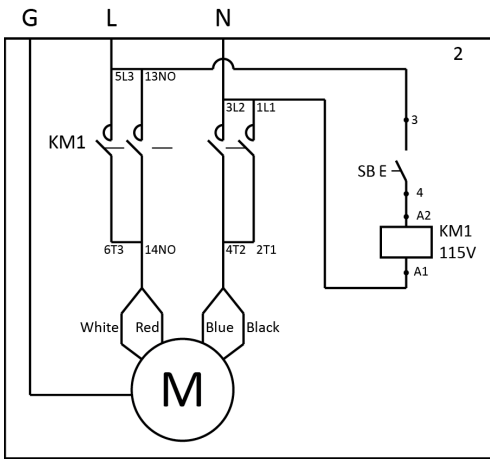

115 VAC

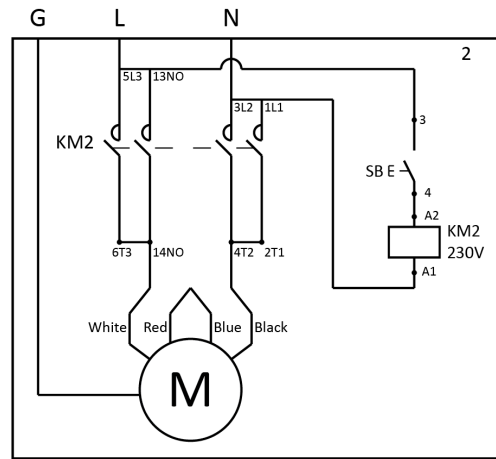

230 VAC

Labels

A



B

BP BendPak 1845 Lemonwood Dr. Santa Paula, CA USA www.BendPak.com

LIFT TYPE: Surface Mount **MANUFACTURER:** BendPak. See data plate for product details
POWER: Electric/Hydraulic **INSTALLATION:** See manual or contact factory

Safety Instructions: If attachments, accessories, or configuration-modifying components that are located in the load path affect operation of the lift, affect the lift electrical listing, or affect intended vehicle accommodation are used on this lift and, if they are not certified for use on this lift, then the certification of this lift shall become null and void. Contact the participant for information pertaining to certified attachments, accessories, or configuration-modifying components.

BendPak lifts are supplied with concrete fasteners meeting the criteria as prescribed by ASTM E488/E488M-18. Lift buyers are responsible for any special regional, structural, and/or seismic anchoring requirements specified by any other agencies and/or codes such as the Uniform Building Code (UBC) and/or International Building Code (IBC).

The manufacture, use, sale, or import of this product may be subject to one or more United States patents, or pending applications, owned by **BendPak Inc.**

PN 5905940
 Do Not Remove Engineered by BendPak Inc., USA Made in China

E

WARNING
VERY IMPORTANT
 TO PROLONG LIFE EXPECTANCY OF CYLINDER SEALS AND PREVENT PREMATURE LEAKAGE AND WEAR, RAISE LIFT TO FULL HEIGHT AT LEAST ONCE A DAY. ALSO, THIS IS AN EFFECTIVE WAY TO BLEED ANY TRAPPED AIR AND MAINTAIN EQUAL LIFTING OF THE SYSTEM.

ATTENTION
TRÈS IMPORTANT
 POUR PROLONGER L'ESPÉRANCE DE VIE DES JOINTS CYLINDRES ET PRÉVENIR LES FUITES PRÉMATURÉES ET PORTEZ, ÉLEVEZ LE PLEIN ÉLEVÉ HAUTEUR AU MOINS UNE FOIS PAR JOUR. AUSSI, C'EST UN EFFICACE FAÇON DE SAIGNER TOUT PIÉGÉ AIR ET MAINTIEN ÉGAL LEVAGE DU SYSTÈME. PN 5905110

C

WARNING
 Read and understand all Danger, Warning, and Caution messages and operation procedures before using lift. Keep hands and feet away from moving parts. Do not work under or near a raised vehicle unless the lift is on a locking position.

OPERATION INSTRUCTIONS
 Before raising a vehicle, make sure the weight of the vehicle does not exceed the rated capacity of the lift, that all persons and obstacles are away from the lift, and that the lift is lowered.

To Raise Lift:
 1. Drive vehicle over lift; there must be at least 1 inch of clearance between vehicle and lift.
 2. Raise the lift until the tires are off the ground.
 3. Make sure the vehicle is balanced and the pads are in contact with the vehicle's lifting points.
 4. Raise the lift to just past the desired height.
 5. Lower the lift down onto the most recently passed locking position. Lock Pin needs to firmly rest against Lock Block, as shown in Figure A.

Before lowering a vehicle, make sure the area around and under the lift is clear of people and obstacles.

To Lower Lift:
 1. Raise the lift up for a second or two. This moves the Release Cam into position so that it can push the Lock Pin over the Lock Block, allowing the lift to lower, as shown in Figure B.
 2. Lower the lift to the ground.
 3. Remove all pads, check under the vehicle for obstacles, then drive the vehicle off the lift.

WARNING
 ALWAYS make sure the lift is firmly in a locked position before working on a raised vehicle.

Figure A LOCKED POSITION

 Release Cam, Lock Block, Lock Bar, Lock Pin

Figure B LOWERING POSITION

 Release Cam, Lock Block, Lock Bar, Lock Pin

PN 5905577

D

WARNING
 Maximum Lifting Capacity
6,000 lbs. / 2722 kg
 FAILURE TO READ AND UNDERSTAND THE FOLLOWING WARNINGS MAY RESULT IN PERSONAL INJURY AND/OR PROPERTY DAMAGE. KEEP HANDS AND FEET AWAY FROM MOVING PARTS.

Read and understand entire contents of operation manual and warnings below before operating this equipment.

- Never exceed rated capacity of the lift.
- Do not operate the lift if any component is defective or worn. If you find a problem, remove the lift from service and get it repaired.
- Never operate lift with any person or equipment below it.
- Drive vehicle completely over lift; make sure vehicle is centered and stable prior to raising or lowering.
- Keep a visual line of sight to the lift during operation.
- Stand clear of the lift during operation.
- Only leave the lift on the ground or on a locking position.
- Keep all body parts and other objects away from pinch points during operation.
- Only use lift on flat, defect-free concrete.
- Always use the lift pads that came with your lift. If a lift pad is missing or damaged, replace it.
- Visually confirm lift is on locking position before working under or near lift.

WARNING
 Before raising a vehicle, make sure there is at least 1 inch of clearance between the lift and the vehicle. The MD-6XP requires space between the ground and your vehicle to build up enough force to raise vehicle. It cannot raise a full load from a completely flat starting position.

WARNING
USE PROPER ADAPTERS
 Do not attempt to lift trucks or other frame type vehicles with standard rubber contact pads. NEVER use lift with missing or damaged rubber contact pads. ALWAYS REPLACE rubber contact pads when worn or damaged. Contact BendPak or your BendPak dealer for product information.

FRAME CRADLE ADAPTERS
 SKUP S215506
 Required for use when lifting trucks, vans or other frame vehicles that require additional stability.

TO PLACE ORDER
 Visit www.bendpak.com or dial 1-800-253-2363 Monday - Friday 6 a.m. - 4:30 p.m. PST
 PN 5905701

F



G

BP BendPak Santa Paula, CA USA www.bendpak.com	
MODEL NUMBER	
DESCRIPTION	
LIFT CAPACITY	DATE OF MFG.
VOLTAGE	
<input type="checkbox"/> 110-240V, 50-60 Hz, 1 Ph <input type="checkbox"/> 208-240V, 50-60 Hz, 1 Ph <input type="checkbox"/> 380-415V, 50-60 Hz, 3 Ph <input type="checkbox"/> 208-440V, 50-60 Hz, 3 Ph	
SERIAL NUMBER	
UPC	
DANGER! Disconnect Power Before Servicing WARRANTY VOID IF DATA PLATE IS REMOVED	

H

<p>CAUTION</p> <p>Lift to be used by trained operator only.</p>	<p>Power Unit: Secure placard near lift controls.</p> <p>Lift Control Console: Secure placard in an accessible location.</p>	<p>5905135</p> <p>The messages and pictographs shown are generic in nature and are meant to generally represent hazards common to all automotive lifts regardless of specific style.</p> <p>Funding for the development and validation of these labels was provided by the Automotive Lift Institute, PO Box 85 Cortland, NY 13045.</p> <p>Replacement label sets may be obtained from the original lift manufacturer and ALIS member companies.</p> <p>They are protected by copyright.</p> <p>www.autolift.org © 2013 by ALI, Inc. ALIWI-308rev</p>
<p>CAUTION</p> <p>Authorized personnel only in lift area.</p>	<p>CAUTION</p> <p>Use vehicle manufacturer's lift points.</p>	<p>CAUTION</p> <p>Always use safety stands when removing or installing heavy components.</p>
<p>NOTICE</p> <p>Read operating and safety manuals before using lift.</p>	<p>NOTICE</p> <p>Proper maintenance and inspection is necessary for safe operation.</p>	<p>NOTICE</p> <p>Do not operate a damaged lift.</p>

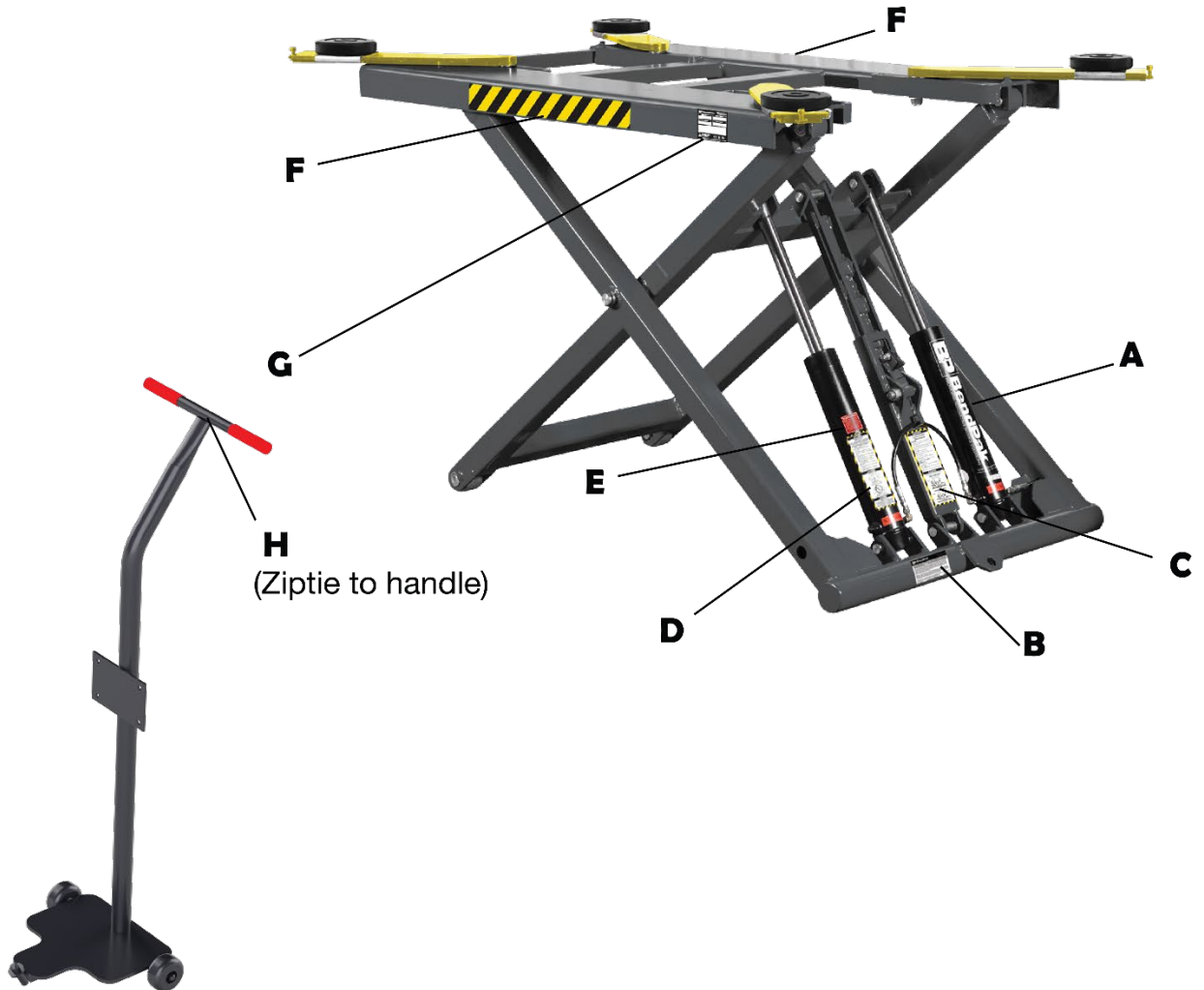

Parts Diagrams

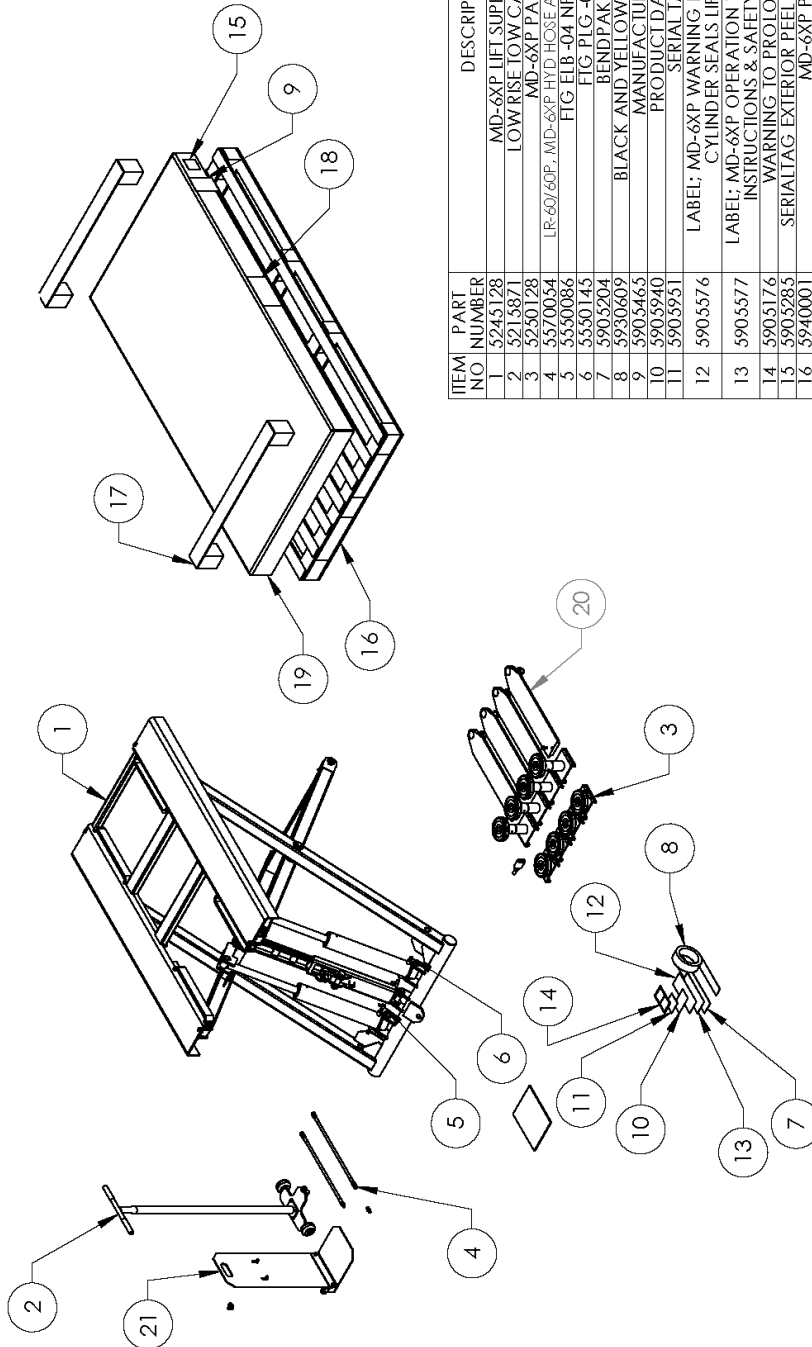

ITEM NO	PART NUMBER	DESCRIPTION	QTY	REV
1	5245128	MD-6XP LIFT SUPERSTRUCTURE	1	M
2	5215871	LOW RISE TOW CART ASSEMBLY	1	B
3	5250128	MD-6XP PARTS BOX	1	W
4	5570054	LR-6076P, MD-6XP HYD HOSE ASSEMBLY Ø6.4 x 540mm DS	1	C
5	5550086	FIG ELB-04 NPT X-04 JIC	2	--
6	5550145	FIG PLG-04 NPT	2	--
7	5905204	BENDPAK LABEL	1	--
8	5930609	BLACK AND YELLOW HAZARD 2" x 10ft	1	--
9	5905465	MANUFACTURER LABEL	1	--
10	5905940	PRODUCT DATA LABEL	1	--
11	5905951	SERIAL TAG.B	1	--
12	5905576	LABEL: MD-6XP WARNING DRIVE CAR OVER LIFT & CYLINDER SEALS LIFE EXPENTANCY	1	--
13	5905577	LABEL: MD-6XP OPERATION WARNING: OPERATION INSTRUCTIONS & SAFETY LOCKED POSITION	1	--
14	5905176	WARNING TO PROLONG LIFE, ENG-FIRE	1	--
15	5905285	SERIALTAG EXTERIOR PEEL OFF-INVENTORY LABEL	1	--
16	5940001	MD-6XP PALLET	1	A
17	5940002	MD-6XP CARRIER BOX CORNER SUPPORT	2	A
18	5905956	MD-6XP PACKAGING LABEL	1	A
19	5781003	MD-6XP CARRIER BOX	1	A
20	5600237	MD-6XP LIFT ARM WELDMENT	4	C
21	5215983	LOW RISE WHEELED POWER UNIT STAND ASSEMBLY	1	A

DO NOT SCALE DRAWING		NAME	DATE
DRAWN	TM	02/19/2009	
CHECKED			
THIRD ANGLE PROJECTION			
DIMENSIONS ARE IN MM			

		1645 LEMONWOOD DR. SANTA PAULA, CA 93060	
TITLE: MD-6XP PRODUCTION LIFT VER B			
SIZE	DWG. NO.	REV	SHEET 1 OF 4
A	5260169	AK	
SCALE: 1:35			

PROPRIETARY AND CONFIDENTIAL
 THE INFORMATION CONTAINED HEREIN IS THE PROPERTY OF BENDPAK INC. ANY REPRODUCTION IN PART OR AS A WHOLE WITHOUT PERMISSION OF BENDPAK INC. IS PROHIBITED.

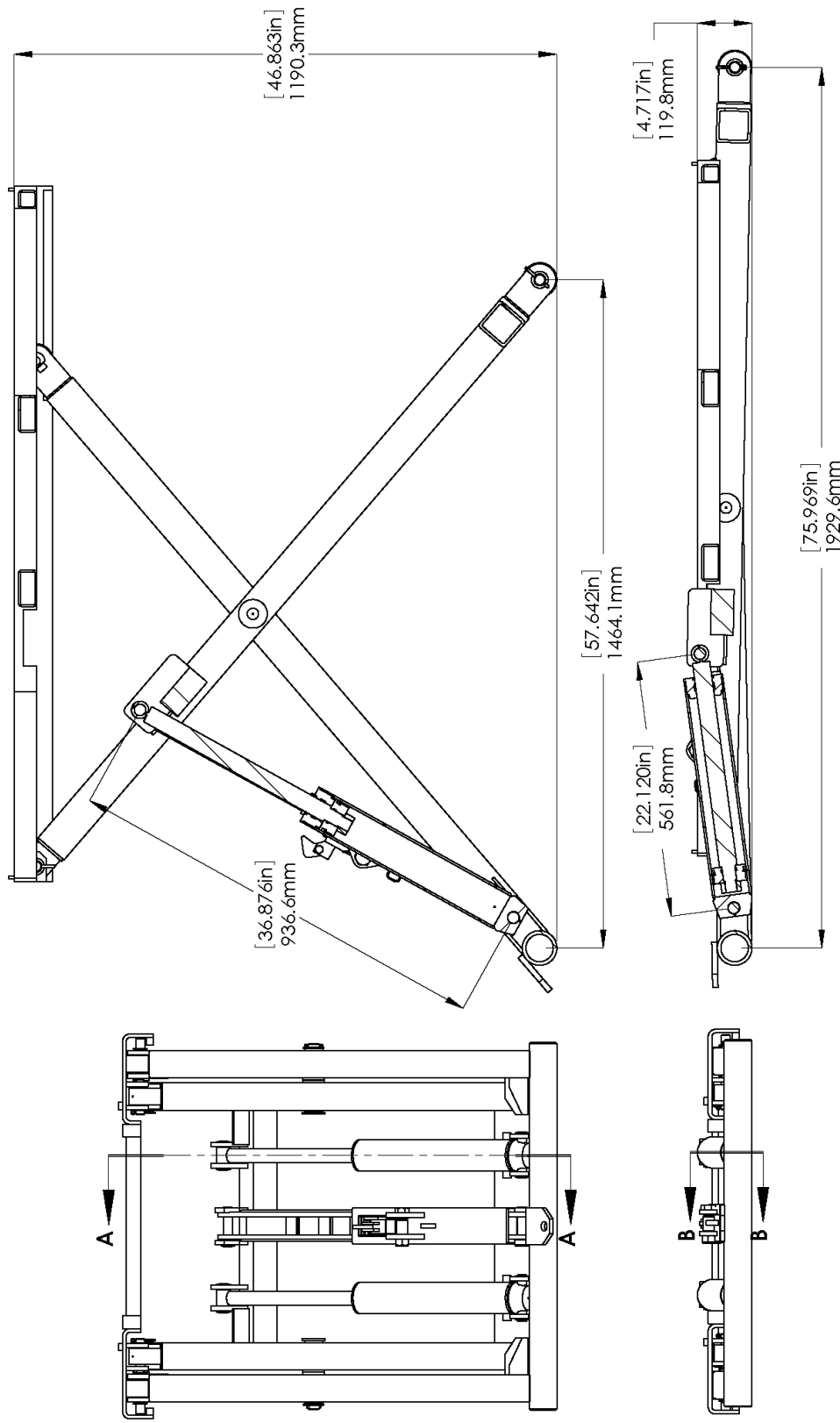

BP BendPak.	
1645 LEMONWOOD DR. SANTA PAULA, CA 95060	
TITLE: MD-6XP PRODUCTION LIFT VER B	
SIZE DWG. NO.	REV
A 5260169	AK
SCALE: 1:12	
SHEET 2 OF 4	

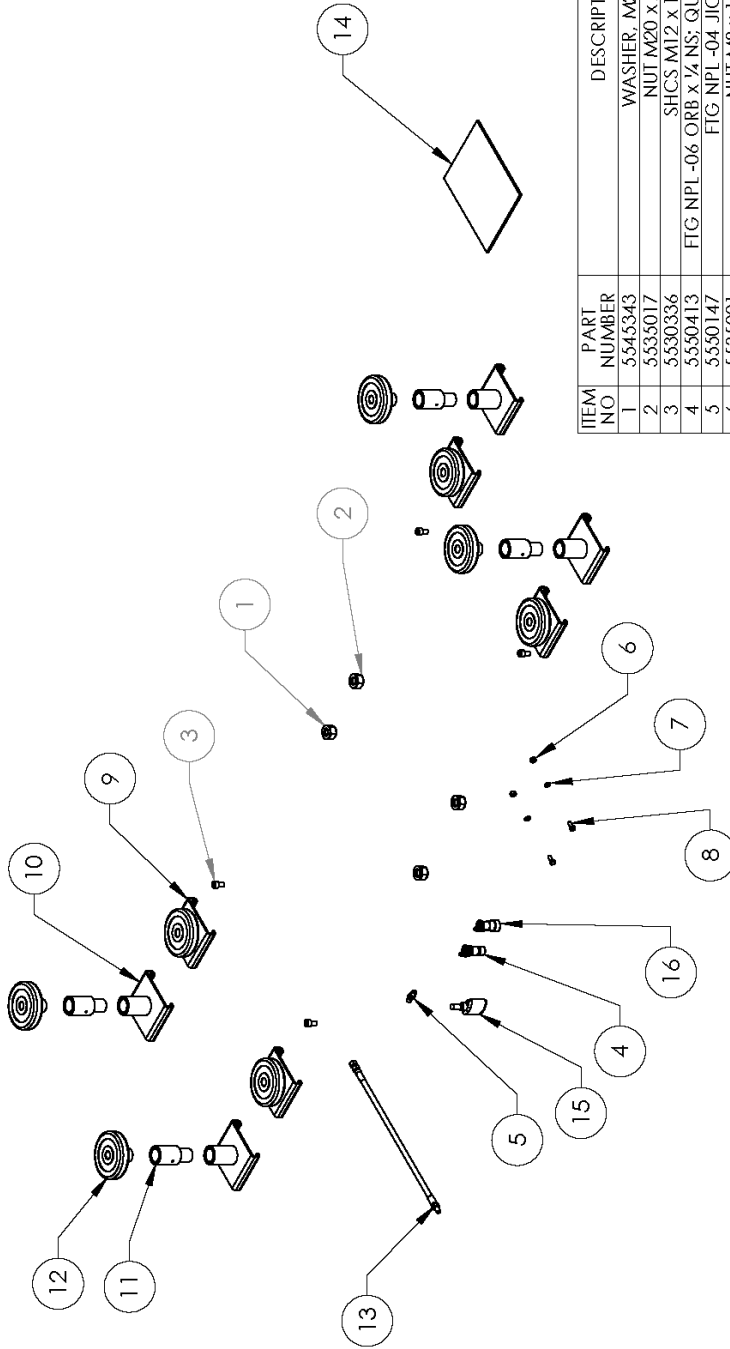

ITEM NO	PART NUMBER	DESCRIPTION	QTY	REV
1	5545343	WASHER, M20 FLAT	4	-
2	5535017	NUT M20 x 2.5 NL	4	-
3	5530336	SHCS M12 x 1.75 x 20	4	-
4	5550413	FIG NPL -06 ORB x 1/4 NS; QUICK-CON COUP MALE	1	B
5	5550147	FIG NPL -04 JIC x-04 NPT	1	-
6	5535001	NUT M8 x 1.25 NL	2	-
7	5545202	WASHER M8 x Ø15 SL	2	-
8	5530304	HHB M8 x 1.25 x 20	2	-
9	5215523	MD-6XP/P9000/RB-J4500 SHORT ROUND LIFT PAD ASSEMBLY	4	G
10	5600257	MD-6XP/P9000/RB-J4500 LIFT PAD WELDMENT BASE	4	D
11	5746390	MEDIUM LIFT PAD EXTENSION Ø35 x 113mm	4	E
12	5215507	ROUND LIFT PAD ADAPTER ASSEMBLY	4	G
13	5570245	HYDRAULIC HOSE ASSEMBLY Ø6.4 x 3.660mm DS-M	1	A
14	5900108	MD-6XP INSTALLATION MANUAL	1	-
15	5580012	LIQUID PTFE THREAD SEALANT 50ml	1	-
16	5550031	FIG NPL-04 NPT F x 1/4 QUICK-CONNECTOR COUPLER FEMALE; NON-SPILL DESIGN	1	B

DO NOT SCALE DRAWING

BP BendPak®
1645 LEMONWOOD DR.
SANTA PAULA, CA 93060

NAME: DATE: 02/18/2009
DRAWN: TM
CHECKED:

THIRD ANGLE PROJECTION

TITLE: MD-6XP PARTS BOX

SIZE DWG. NO. A 5250128
REV W

DIMENSIONS ARE IN MM

PROBREM AND CONFIDENTIAL
THE INFORMATION CONTAINED IN THIS DRAWING IS THE PROPERTY OF BENDPAK INC. AND IS TO BE USED ONLY FOR THE PROJECT AND QUANTITY SPECIFIED WITHOUT THE WRITTEN PERMISSION OF BENDPAK INC. IS PROHIBITED.

SCALE: 1:18 SHEET 1 OF 1

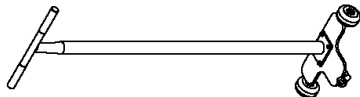
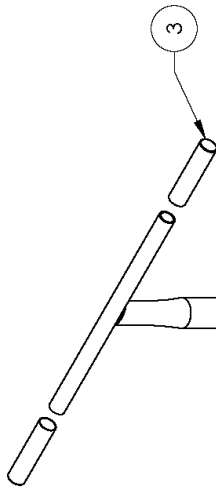

ISOMETRIC VIEW
FOR REFERENCE ONLY
DO NOT SCALE

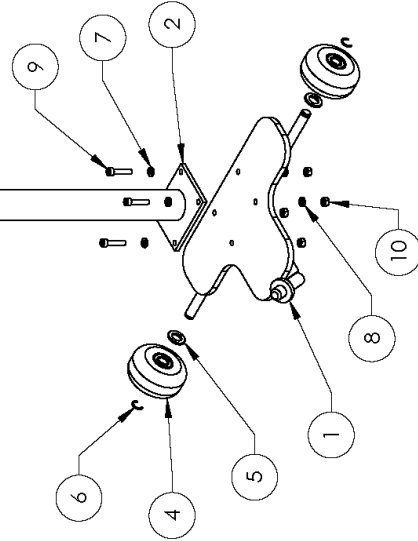
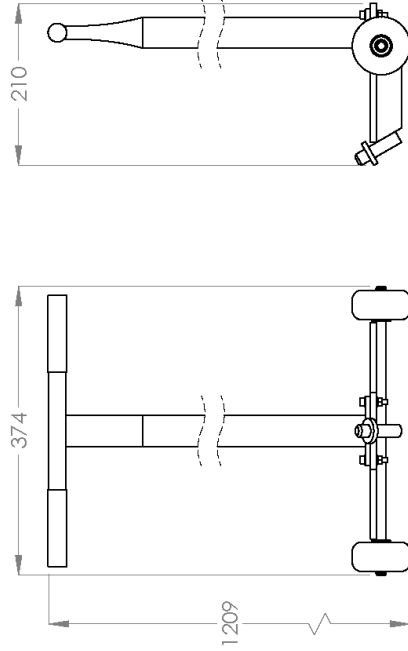

ITEM NO	PART NUMBER	DESCRIPTION	QTY	REV
1	5601405	LOW RISE TOW CART BASE WELDMENT	1	A
2	5601406	LOW RISE TOW CART HANDLE WELDMENT	1	A
3	5715343	LOW RISE TOW CART PLASTIC HANDLE COVER	1	B
4	5215872	LOW RISE TOW CART PLASTIC WHEEL ASSEMBLY	2	B
5	5545347	WASHER, M1/2 FLAT WASHER	2	--
6	5540116	TRUARC Ø12mm 5103-50	2	--
7	5545026	WASHER M6 x Ø12 SL	4	--
8	5545005	M6 FLAT WASHER	4	--
9	5400959	SHCS M6 x 1.0 x 30	4	--
10	5555357	NUT M6 x 1.0 NL	4	--

DO NOT SCALE DRAWING

NAME: TM
DATE: 09/12/2019
DRAWN: CA
CHECKED: 11/1/2019

THIRD ANGLE PROJECTION

TITLE: LOW RISE TOW CART ASSEMBLY

SIZE DWG. NO. A 5215871

REV B

SHEET 1 OF 1

SCALE: 1:8



PROBABILITY AND CONFIDENTIALITY
THE SOLE PROPERTY OF BENDPAK INC. ANY
REPRODUCTION OR TRANSMISSION OF THIS
DRAWING WITHOUT THE WRITTEN PERMISSION OF
BENDPAK INC. IS PROHIBITED.



1645 LEMONWOOD DR.
SANTA PAULA, CA 93060

Automotive Lift Institute (ALI) Store

You probably checked the [ALI's Directory of Certified Lifts](http://www.autolift.org/ali-directory-of-certified-lifts/) (www.autolift.org/ali-directory-of-certified-lifts/) before making your most recent Lift purchase, but did you know the **ALI Store** (www.autolift.org/ali-store/) offers a wide variety of professional, easy-to-use, and reasonably priced training and safety materials that will make your garage a safer place to work?

The ALI Store is your trusted source for workplace safety!

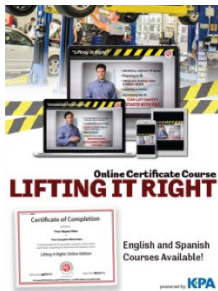

Lifting It Right Online Certificate Course. Make *sure* you and your people are lifting vehicles the right way.



KPA Online Training Subscription. Get all of your people up to speed on automotive industry topics.

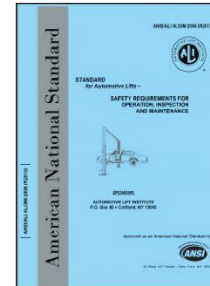

ANSI/ALI ALOIM Standard for Automotive Lifts. Safety Requirements for Operation, Inspection, and Maintenance.

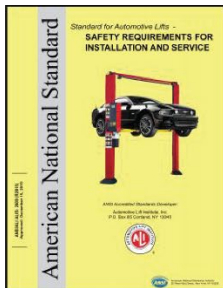

ANSI/ALI ALIS Standard. Safety Requirements for Installation and Service.

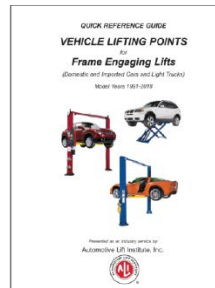

Guide to Hitting Vehicle Lifting Points for Frame-Engaging Lifts. Don't eyeball your lifting points, *know* where they are.



Lift Operator Safety Materials. Five safety documents in a single package.

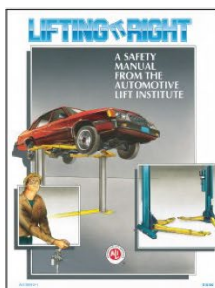

Lifting It Right. A hardcopy version of the *Lifting It Right* safety manual from the Automotive Lift Institute.



Uniform Warning Labels and Placards for 2-Posts. Labels in Mandarin, French Canadian, and Spanish are also available.



Safety Tips Card. Reminds your people of 13 key safety tips to follow daily.

Visit today and get the training and materials you need to work safely:
www.autolift.org/ali-store/.



1645 Lemonwood Drive
Santa Paula, CA 93060 USA